



MICRONETICS

Test Solutions Group



**Carrier-to-Noise Generator Operating
Manual
VOLUME 1:
User's Guide**

MICRONETICS TEST SOLUTIONS GROUP
CNG Operating Manual
VERSION 2.0 MAY 2004

© Micronetics Test Solutions Group
26 Hampshire Drive Hudson, NH 03051
Phone 603.883.2900 • Fax 603.882.8987

Using this Manual

This manual provides details on the use of the Micronetics CNG-77xx series Carrier-to-Noise Generators (CNG). This manual is written to cover several CNG models furnished with the CNGOS operating system. As such, some functions and features discussed in this manual will not be available on certain product models. Every effort is made throughout this manual to denote these functions and features as being optional or not available on some models.

The CNG manual is partitioned into Volumes and organized into the following sections or chapters:

VOLUME 1: User's Guide

Quick Start Chapter 1 helps you get familiar with the most important functions and features of the CNG guiding you through a typical setup sequence.

General Information Chapter 2 contains a general description of the CNG including important information on Safety Considerations. This chapter also provides instructions for installation of your CNG and hardware connections.

Front Panel Operation Chapter 3 describes in detail how to operate the CNG through the front-panel keys. This chapter also describes the CNG calibration process and shows how to configure the CNG for remote operation.

Remote Interface Reference Chapter 4 contains reference information to help you in controlling the CNG through the remote interface.

VOLUME 2: Product Specifications and Tests

Theory of Operation Chapter 5 discusses the theory of operation behind the CNG. It is intended as a more technical reference for those interested in the calculations being performed by the CNG during its normal operation.

Specifications Chapter 6 lists the specifications for this specific CNG Model and configuration.

Performance Tests Chapter 7 contains details on the testing performed by the factory on this specific CNG to ensure it is meeting the performance specifications. Results of these tests are contained in an Appendix to this Volume of the Manual.

VOLUME 3: Servicing and Calibration

Service Information **Chapter 8** contains procedures for CNG troubleshooting and guidelines on returning your CNG to Micronetics for servicing and factory calibration.

Field Calibration **Chapter 9** provides details on the utilities included in the CNGOS that allow for partial calibration of the CNG at facilities outside of the Micronetics factory. These utilities are provided to verify the integrity of the CNG's performance at intervals interim to the Micronetics Factory Calibrations.

If you have questions relating to the operation of the Carrier-to-Noise Generator, call 1-603-883-2900 in the United States, or contact your nearest Micronetics Sales Representative.

If your CNG fails within one year of purchase, Micronetics will repair it free of charge. Call 1-603-883-2900 in the United States, or contact your nearest Micronetics Sales Representative.

Table of Contents

USING THIS MANUAL	III
VOLUME 1: User's Guide.....	iii
VOLUME 2: Product Specifications and Tests	iii
VOLUME 3: Servicing and Calibration	iv
QUICK START	1
FRONT PANEL AT A GLANCE.....	2
FRONT-PANEL KEY REFERENCE.....	3
LCD DISPLAY AT A GLANCE.....	4
LCD DISPLAY KEY REFERENCE	5
REAR PANEL AT A GLANCE.....	6
REAR-PANEL KEY REFERENCE.....	7
POWERING UP THE CNG.....	8
FAILURE TO POWER UP.....	8
UNIT WARM-UP.....	8
SYSTEM CALIBRATION.....	8
SYSTEM CALIBRATION FAILURE	9
System Calibration Checklist.....	9
TYPICAL SET-UP SEQUENCE.....	11
TYPICAL SET-UP SEQUENCE.....	14
GENERAL INFORMATION	17
SAFETY CONSIDERATIONS	17
PRODUCT DESCRIPTION.....	17
INITIAL INSPECTION	18
INSTALLATION & PREPARATION FOR USE.....	19
Power Cord.....	19
RF Connections.....	19
Remote Interface.....	19
Operating Environment.....	19
Bench Operation	20
Rack Mounting.....	20
FRONT PANEL OPERATION	21
MAIN DISPLAY LAYOUT.....	21
DIRECT SOFTKEY CONTROLS.....	23
Key 1: Set Mode.....	23
Key 2: Adjust Carrier Output.....	24
Key 2: Adjust Noise Density	24
Key 2: Adjust Injector Output (Injector Option Only).....	24
Key 2: Measure Injector Input (Injector Option Only).....	25
Key 3: Bit Rate.....	25
Key 3: Injector Frequency (Injector Option Only).....	25
Key 4: Injector Bandwidth.....	26
Key 5: Perform System CAL.....	26
Key 6: Set Ratio.....	26
Key 6: Set Noise Density	27
Key 6: Set Carrier Output	27
Key 6: Set Injector Output (Injector Option Only).....	27
Key 7: Modulation Factor	28
Key 7: Attenuator Step Size.....	28
Key 8: Center Frequency.....	28
Key 9: DUT Bandwidth.....	29
Key 0: Turn Noise ON / OFF.....	29
Key 0: Turn Carrier ON / OFF.....	29
Key 0: Turn Injector ON / OFF (Injector Option Only).....	30
DATA WINDOWS.....	30
Carrier @ Output.....	30
Noise Density.....	31
Carrier + Noise @ Output.....	31
Noise Power @ Output.....	31
Inject Power @ Output (Injector Option Only)	31
Carrier + Injector @ Output (Injector Option Only)	31
SYSTEM BLOCK DIAGRAM.....	32
PULL-DOWN MENUS.....	33
Shortcut Keys.....	33
FILE Menu.....	34
MODE Menu.....	34
OPTIONS Menu.....	35
SYSTEM Menu.....	38
HELP Menu.....	39
REMOTE INTERFACE REFERENCE	41
GPIB (IEEE-488) HARDWARE INTERFACE.....	41
GPIB Electrical Signal Configuration.....	42
Talkers, Listeners and Controllers.....	43
RS-232 (SERIAL) HARDWARE INTERFACE.....	44
RS-232 Electrical Signal Configuration.....	44
RS-232 Data Frame Format	45
Connection to a Computer or Terminal	45
GENERAL PROGRAMMING GUIDELINES	46
Remote Configuration	46
Command Structure.....	46
Command Language.....	47
System Address	47
REMOTE COMMAND SET – SCPI.....	48
SCPI Command Syntax	48
SCPI Command Terminators.....	48
488.2 Common Commands.....	49
System Level Commands.....	50
Mode Commands.....	53
Ratio Commands.....	54
Carrier Path Commands.....	55
Carrier Path Factory Commands.....	57
Noise Path Commands.....	58
Noise Path Factory Commands.....	60
Injector Path Commands.....	61
Options Menu Commands.....	62
Combined Output Commands.....	63
Power Sampling Factory Commands.....	63
GPIB Only Commands	63
Remote Error Codes.....	64
LEGACY COMMAND CROSS REFERENCE	65

Quick Start

Key information to help you start quickly on using your Carrier-to-Noise Generator.

This chapter is designed to get you acquainted with the key features of the Micronetics Carrier-to-Noise Generator (hereafter referred to as the CNG) and guide you through a typical setup sequence. Topics covered here include:

- Front Panel at a Glance
- LCD Display at a Glance
- Rear Panel at a Glance
- Power Connection / Power Up
- System Warm-up
- System Calibration
- Typical Setup Sequence

More detailed information on each setup parameter, optional menu features, and remote operation can be found in the chapters that follow.

Front Panel at a Glance

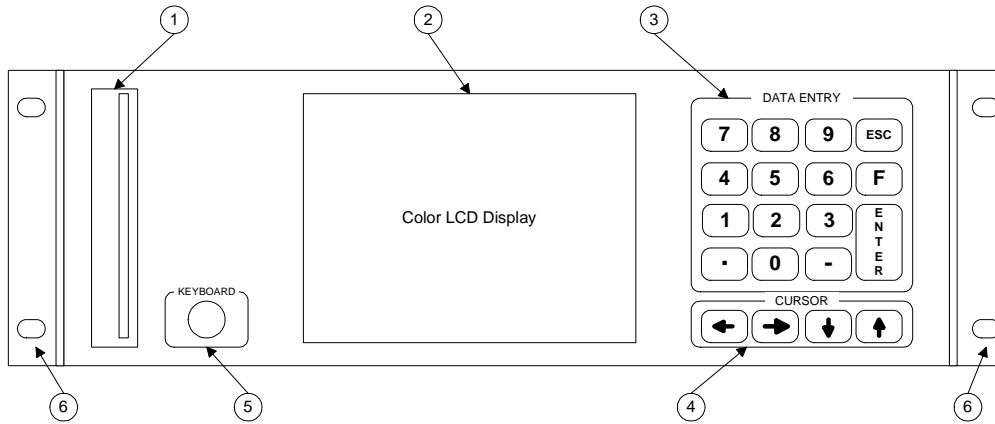

1 Floppy Disc Drive (3.5 inch)

2 Color LCD Display

3 Data Entry Keypad

4 Cursor Keys

5 External Keyboard Connection

6 Rack Mount Flanges

Front-Panel Key Reference

This section gives an overview of the front-panel features. All CNG front panel and operating system are designed to provide direct keypad access to more commonly used functions or parameters and keypad and cursor access via pull-down menu options for less frequently used items. All CNG parameters required to configure a particular function or operation are available via the front panel.

- 1 Floppy Disc Drive (3.5 inch) Allows for field update of system related files.
- 2 Color LCD Display Provides display of hardware configuration, direct access system parameters, pull-down menus, unit serial number, current instrument state, current system impedance, remote interface status and system time date clock.
- 3 Data Entry Keypad The data entry keypad performs various functions depending upon the current operation being performed:
 - Keys 0 to 9: Activate corresponding softkey for data entry. Provide direct numeric input during dialog box entry.
 - Decimal Key: Provides direct entry of decimal point in numeric entry.
 - Minus Key: Changes sign of current numeric entry. Key can be pressed at any time during numeric entry and sign will toggle from plus to minus or minus to plus.
 - ESC Key:¹ Cancels any parameter entry currently in progress. Key also clears any pull-down menu activity that may be in progress.
 - F Key: Accesses the CNG's pull-down menus. This key has serves as a Backspace key during any dialog box entry.
 - ENTER Key: Completes any parameter entry currently in progress.
- 4 Cursor Keys The Left, Right, Up and Down cursor keys are used to navigate through the CNG's pull-down menus. The Down key will initially pull-down the currently selected menu branch and then allow sequential movement down through the current menu choices. The Up key moves upward through the menu choices once the menu has been initially pulled down with the Down key. The Left and Right keys allow movement through the menu branches and in some cases into or out of secondary menu branches of a main branch parameter.
- 5 External Keyboard Connection This allows connection of the external keyboard supplied with the CNG. For most CNG typical operations, the keyboard is not required to be connected.
- 6 Rack Mount Flanges The CNG is supplied with rack mount flanges as a standard accessory. These flanges allow installation of the CNG into a standard EIA 3U high 19-inch rack location.

¹ The key can be used as the "LOCAL" key when the CNG is in the remote interface mode.

LCD Display at a Glance

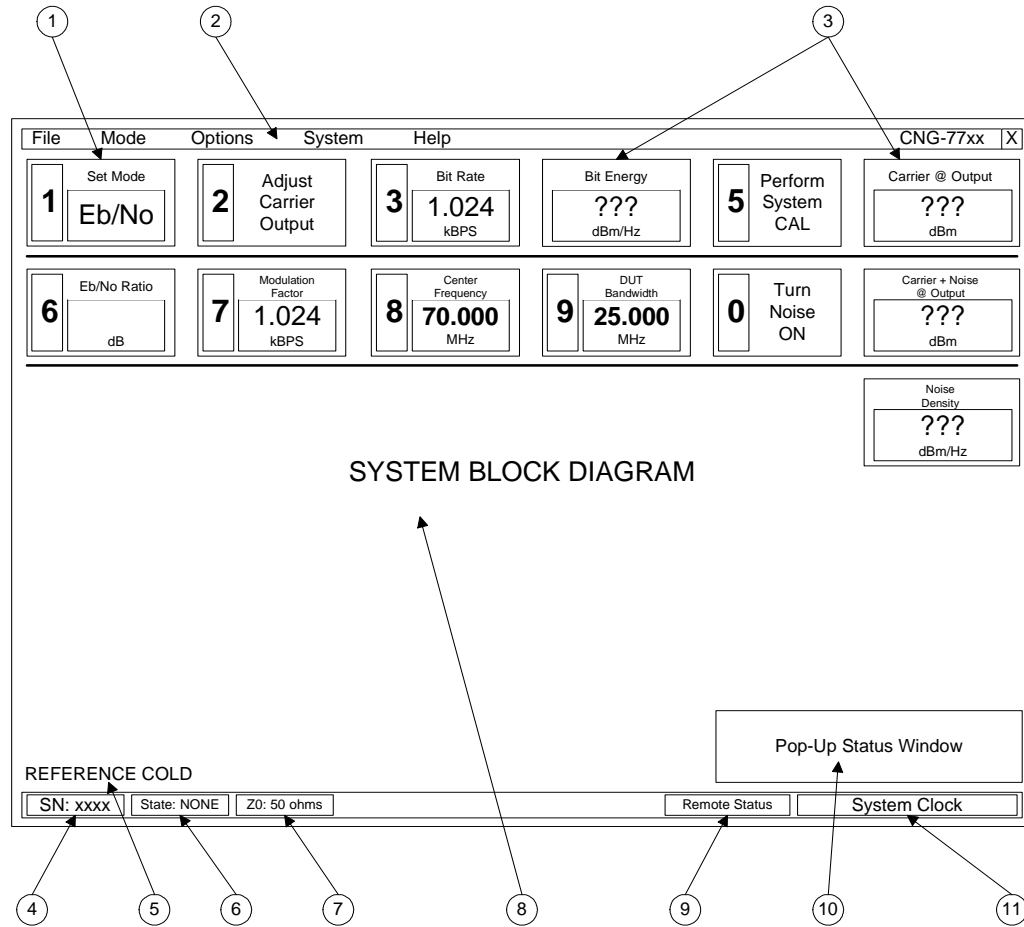

- | | |
|---------------------------|---------------------------|
| 1 Softkey Display Window | 7 System Impedance Window |
| 2 Main Menu Bar | 8 System Block Diagram |
| 3 Data Display Window | 9 Remote Interface Status |
| 4 Serial Number Window | 10 Status Pop-up Window |
| 5 Warm-up Message | 11 System Clock Window |
| 6 Instrument State Window | |

LCD Display Key Reference

This section provides an overview of the features contained in the LCD Display Area. The diagram shows a typical CNG display screen for a particular mode. The display's specific content will change depending upon the current CNG mode and particular CNG model.

- 1 **Softkey Display Window** This window signifies that the key number contained on the left of the window is associated with the function, parameter or action labeled in the upper right portion of the display window. The current setting or state of the function or parameter is indicated in the lower right portion of the display window.
- 2 **Main Menu Bar** This represents the top portion of the CNG's pull-down menu system. The Menu is initially accessed using the F key on the keypad and then navigated using the LEFT, RIGHT, UP and DOWN cursor keys.
- 3 **Data Display Window** This window provides status information in the lower portion of the display window for the parameter indicated in the upper portion of the display window.
- 4 **Serial Number Window** The unique serial number of this CNG is displayed here.
- 5 **Warm-up Message** The message displayed for the first 15 minutes since CNG power up indicating the unit is still warming up for use.
- 6 **Instrument State Window** This window indicates the instrument state register currently recalled from system memory.
- 7 **System Impedance Window** The current system impedance is indicated here.
- 8 **System Block Diagram** A pictorial view of the CNG hardware configuration and current status. This diagram is specific to the CNG model. The current setting for path attenuators and RF switches is indicated in this diagram.
- 9 **Remote Interface Status** This window shows which remote interface is currently selected (for example, GPIB or RS-232) and its present status. If the R LED is red, the CNG is in remote mode. All front panel and external keyboard keys except ESC are disabled. Pressing the ESC key will return the CNG to local mode.
- 10 **Status Pop-up Window** Throughout the use of the CNG several status windows may appear in this location or alternately in the upper left portion of the display area. These messages are intended to provide operator feedback during more time-consuming operations.
- 11 **System Clock Window** If enabled, the System Clock (date and time) will be displayed here.

Rear Panel at a Glance

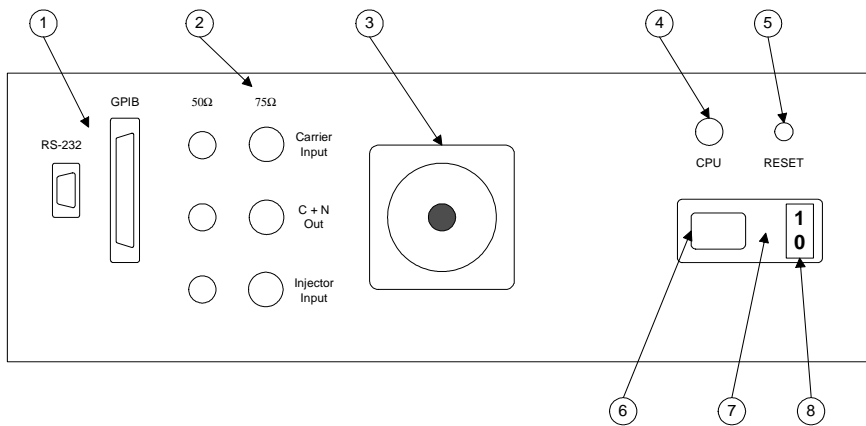

1 Remote Interface Connections

2 RF Input / Output Connections

3 Cooling Fan

4 CPU Ready LED

5 System CPU Reset Button

6 AC Power Cord Inlet

7 AC Input Fuse Holder

8 AC Power ON/OFF Switch

Rear-Panel Key Reference

This section gives an overview of the rear-panel features. The diagram represents a typical CNG configured with options for the RS-232 Remote Interface and Dual RF Impedance. Not all CNG Models will contain rear-panel features as depicted here. Some Models may also utilize alternate types of connectors for the RF Input/Output interfaces.

- 1 Remote Interface Connections The CNG may possess one or more interfaces for remote operation. Depicted here are the GPIB (IEEE-488) and RS-232 interface connectors.
- 2 RF Input/Output Connections The typical CNG comes configured with a single set of RF connectors for Carrier Input, C+N Output and, optionally, an Injector Input. The diagram depicts an optional configuration for Dual RF Impedance which then adds an additional set of Input(s)/Output connectors for the second impedance.
- 3 Cooling Fan The cooling fan provides airflow thru the CNG to maintain an acceptable operating temperature. Care should be taken so as not to obstruct the fan's operation. The cooling fan assembly also contains a dust filter that requires periodic cleaning to prevent airflow restriction.
- 4 CPU Ready LED This LED will be illuminated green when power is being applied to the system CPU.
- 5 System CPU Reset Button This push button initiates a powered re-boot of the system CPU.
- 6 AC Power Cord Inlet This receptacle accepts a standard three-terminal AC power line cord. Power cords **MUST** provide proper connection of chassis to earth ground via a three-terminal plug.
- 7 AC Input Fuse Holder The AC Power Module contains the in-line fuse for the AC power input. The fuse can be accessed only if the AC power cord is removed.
- 8 AC Power ON/OFF Switch The main AC power can be switched ON/OFF via this switch.

Powering up the CNG

The CNG is a Class I instrument equipped with a protective earth terminal. That terminal must be connected to earth ground through a power source with a 3-wire ground receptacle.

Before installation or operation, check the CNG and review this manual for safety markings and instructions. Safety information for specific procedures is located at the appropriate places in the manual.

To power up the CNG, connect the CNG to the AC Mains voltage with the AC power cord provided. The CNG has an auto-sensing power supply that accepts voltages from 90 to 250 Volts AC.

With the CNG connected to AC power via a 3-wire ground receptacle, turn on the power switch located on the rear panel. The CNG system CPU will begin to boot and automatically launch the CNG Operating System.

Failure to Power Up

If the CNG fails to power up, consult the Service section of this manual.

Unit Warm-up

It is recommended that the CNG be allowed to warm-up a minimum of 15 minutes, 30 minutes preferred, prior to performing system calibration and measurement setup. A message labeled REFERENCE COLD will be displayed in the lower left corner of the CNG Display for the first 15 minutes from initial power-up.

System Calibration

The CNG must complete an internal system calibration prior to setup for use in any measurements. The CNG will indicate that calibration is required by flashing the System Calibration Softkey (Key 5). To complete a system calibration perform the following steps:

1. Present the Carrier Input connector of the CNG with an impedance matching the current system impedance (50 or 75 ohms).
2. Connect the C+N Output connector to a load impedance matching the current system impedance (50 or 75 ohms).

3. Press Key 5 on the CNG Data Entry keypad to initiate the System Calibration. The CNG will prompt for confirmation. Press the ENTER key to confirm the System Calibration or press the ESC key to cancel.
4. The calibration process consists of three steps:
 - a. Zeroing the internal power meter.
 - b. Calibrating the internal power meter.
 - c. Measuring the reference level of the internal noise source.

The CNG will report status in a pop-up window in the lower right corner of the CNG LCD display.

Once the CNG successfully completes the calibration process, the System Calibration Softkey will stop flashing.

The Calibration process can be aborted prior to completion by pressing the ESC key. A message will be displayed to indicate that the process is being terminated per user request.

System Calibration Failure

If the calibration failed, the System Calibration Key will continue to flash. Verify that the following conditions have been met prior to initiating the calibration process. If not, correct any conditions and attempt the calibration again.

System Calibration Checklist

- **Carrier Input Termination:** Ensure that the CNG has a matched load connected to the CNG's Carrier Input Port. For single impedance CNG Models, ensure that the load provided is the same as the system impedance (50 or 75 Ohms). For a CNG equipped with the Dual Impedance Option, ensure that the matched load has been installed on the port associated with the currently selected System Impedance (see lower left portion of CNG Display's Status Bar).
- **C+N Output Termination:** Ensure that the CNG has a matched load connected to the CNG's C+N Output Port. For single impedance CNG Models, ensure that the load provided is the same as the system impedance (50 or 75 Ohms). For a CNG equipped with the Dual Impedance Option, ensure that the matched load has been installed on the port associated with the currently selected System Impedance (see lower left portion of CNG Display's Status Bar).
- **Warm-up Time:** Ensure that the CNG has been powered up for a minimum of 15 minutes. If the RFEFERENCE COLD message still appears in the lower left

portion of the CNG Display, the CNG has not been powered up for the minimum 15 minutes.

- Noise Reference Error: Determine if system calibration failed due to Noise Reference by viewing the CNG factors. The current factors can be viewed by selecting View Factors from the System Menu (or pressing the V key if the external keyboard is attached). If the Noise Reference Error (number in parentheses) is greater than 2.0 dB in magnitude, the CNG will flag the system calibration as failing.

If the CNG continues to fail the system calibration, consult the Service section of this manual for further instructions.

Typical Set-up Sequence

C/N, C/No, Eb/No, C/I Modes

This section shows the recommended sequence for setting up the CNG for a typical ratio measurement requirement. Following the steps in the sequence outlined below will ensure that the CNG is configured properly for the desired settings.

- 1 **System Calibration** Ensure that the CNG has completed an internal System Calibration (see System Calibration section above).
- 2 **Set Mode** Press Key 1 to bring up the list of possible modes of operation. Use the UP and DOWN cursor keys to highlight the desired mode. Press the ENTER key to activate the highlighted mode. For a detailed description of each operating mode, please refer to the Front Panel Operation section of this manual. The Softkey 1 Display Window will update to reflect the mode just selected.
- 3 **Select Constant Parameter** It may be necessary to choose which parameter will be independently controlled by the operator. The constant parameter is determined by selecting the Options Menu and viewing the current setting for Const: xxxx. The Softkey 2 Display Window also provides an indication of the currently selected parameter as follows:
 - a. No Softkey 2 Display Window – inherently indicates that the CNG does not have a Carrier Path Attenuator and, as such, the Carrier is the constant or independent parameter.
 - b. Set Carrier Level – indicates Carrier is the constant or independent parameter. (Only available if CNG is equipped with Carrier Path Attenuator.)
 - c. Set Noise Density – indicates Noise is the constant or independent parameter. (Only available if CNG is equipped with Carrier Path Attenuator.) Not available in C/I mode.
 - d. Set Injector Level – indicates Injector is the constant or independent parameter. (Only available if CNG is equipped with Carrier Path Attenuator and Injector Input Option.) Only available in C/I mode.

The constant parameter can be changed from its current setting by accessing the Options Menu. To access the Options Menu first press the Data Entry Keypad F Key. The File menu will drop down from the menu bar located at the top of the LCD display window. Using the RIGHT cursor key, move across to the Options menu. Using the DOWN cursor key, highlight the Const: xxxxxx menu item, where xxxxxx is the currently selected constant parameter such as CARRIER or NOISE. The sub-menu will then appear and can be accessed by pressing the RIGHT cursor key one more time. Using the UP / DOWN cursor keys, highlight

the parameter to be selected as constant. Press the ENTER key to complete the selection. The Softkey 2 Display Window will update to reflect the chosen parameter.

- 4 Set Center Frequency Press Key 8 to set the CNG Center Frequency to reflect the Carrier Input Signal's frequency. Follow the instructions provided in the input dialog box pressing ENTER to complete the entry. The Softkey 8 Display Window will update to report the entered value of Center Frequency.
- 5 Set DUT Bandwidth Press Key 9 to set the Noise Equivalent Bandwidth of the Device Under Test (DUT). Follow the instructions provided in the input dialog box pressing ENTER to complete the entry. The Softkey 9 Display Window will update to report the entered value for DUT Bandwidth.
- 6 Set Constant Parameter Level Press Key 2 to set the level of the constant parameter selected in Step 3. Follow the instructions provided in the input dialog box pressing ENTER to complete the entry. The CNG will adjust the path attenuator to the value required to set the desired level. The appropriate Data Display Window (Carrier Out, Noise Out or Injector Out) will update to reflect the actual level achievable that is closest to the desired level. The independent or constant parameter will then be "anchored" to this reported level. If the CNG is set for C/I mode, proceed to Step 8. If the CNG is set for C/N or C/No mode, proceed to Step 10.
- 7 Set Bit Rate (Eb/No ONLY) Press Key 3 to set the Bit Rate for the Carrier Input signal. This parameter is only required if Eb/No mode was selected in Step 1. Follow the instructions provided in the input dialog box. Note that this entry is made in exponential format with the UP cursor key used to enter the "E" character. Press enter to complete the entry. The Softkey 3 Display Window will update to report the entered value for Bit Rate. If a Carrier Input signal is also present, the Bit Energy Data Window will update to account for the Bit Rate setting. Proceed to Step 10.
- 8 Set Injector Frequency (C/I ONLY) Press Key 3 to set the CNG Injector Center Frequency to reflect the Injector Signal's frequency. This parameter is required only if C/I mode was selected in Step 1. Follow the instructions provided in the input dialog box pressing ENTER to complete the entry. The Softkey 3 Display Window will update to report the entered value for Injector Center Frequency.
- 9 Set Injector Bandwidth (C/I ONLY) Press Key 4 to set the Bandwidth of the Injector Signal. This parameter is required only if C/I mode was selected in Step 1. Follow the instructions provided in the input dialog box pressing ENTER to complete the entry. The Softkey 4 Display Window will update to report the entered value for Injector Signal Bandwidth. Simply use a value of 1kHz for a CW signal.

- 10 Set Ratio Press Key 6 to set the desired ratio. Follow the instructions provided in the input dialog box pressing ENTER to complete the entry. The CNG will then adjust the dependent path attenuator to the value necessary to reach the desired ratio. The Softkey 6 Display Window will update to report the actual ratio established by the CNG. This represents the closest achievable value to the desired setting.
- 11 Noise ON/OFF (Injector ON/OFF) Press Key 0 to toggle the Noise (C/N, C/No, Eb/No) or Injector (C/I) signal ON/OFF at the CNG C+N Output. The Softkey 0 Display Window shows a Green background when the signal is ON and a Red background when the signal is OFF.

The CNG's current setup is reported via the collection of Softkey and Data Display Windows contained on the LCD Display.

It is strongly recommended that if any parameter or setting is altered that all steps that follow the parameter's associated step be repeated. For example, setting a new ratio (Step 10) would not require any additional steps. However, setting a new level for the Constant Parameter (Step 6) would require repeating Step 10 as well.

Typical Set-up Sequence

Carrier Only, Noise Only, Injector Only Modes

This section shows the recommended sequence for setting up the CNG for a typical single parameter mode. Following the steps in the sequence outlined below will ensure that the CNG is configured properly for the desired settings.

- 1 System Calibration Ensure that the CNG has completed an internal System Calibration (see System Calibration section above).
- 2 Set Mode Press Key 1 to bring up the list of possible modes of operation. Use the UP and Down cursor keys to highlight the desired mode. Press the ENTER key to activate the highlighted mode. For a detailed description of each operating mode, please refer to the Front Panel Operation section of this manual. The Softkey 1 Display Window will update to reflect the mode just selected. In Carrier Only mode the Noise / Injector path is fully attenuated. In Noise Only mode the Carrier path is fully attenuated. In Injector Only mode the Carrier path is fully attenuated and the internal Noise source is switched to an internal termination.
- 3 Set Center Frequency Press Key 8 to set the CNG Center Frequency to reflect the Carrier Input Signal's frequency. Follow the instructions provided in the input dialog box pressing ENTER to complete the entry. The Softkey 8 Display Window will update to report the entered value of Center Frequency.
- 4 Set DUT Bandwidth Press Key 9 to set the Noise Equivalent Bandwidth of the Device Under Test (DUT). Follow the instructions provided in the input dialog box pressing ENTER to complete the entry. The Softkey 9 Display Window will update to report the entered value for DUT Bandwidth.
- 5 Set Attenuator Step Size Press Key 7 to set the desired step size for the path attenuator. Follow the instructions provided in the input dialog box pressing ENTER to complete the entry. The entered parameter will be adjusted as necessary to the nearest achievable value based on the physical hardware installed in this CNG model. The Softkey 7 Display Window will update to reflect this actual level. If Carrier Only or Noise Only mode is selected, proceed to Step 8.
- 6 Set Injector Frequency (Injector ONLY) Press Key 3 to set the CNG's Injector Center Frequency to reflect the Injector Signal's frequency. This parameter is required only if C/I mode was selected in Step 1. Follow the instructions provided in the input dialog box pressing ENTER to complete the entry. The Softkey 3 Display Window will update to report the entered value for Injector Center Frequency.

- 7 Set Injector Bandwidth (Injector ONLY) Press Key 4 to set the Bandwidth of the Injector Signal. This parameter is required only if C/I mode was selected in Step 1. Follow the instructions provided in the input dialog box pressing ENTER to complete the entry. The Softkey 4 Display Window will update to report the entered value for Injector Signal Bandwidth.
- 8 Set Level Press Key 6 to set the desired output level for the parameter. Follow the instructions provided in the input dialog box pressing ENTER to complete the entry. The CNG will then adjust the path attenuator to the value necessary to reach the desired level. The appropriate Display Window (Carrier Out, Noise Out or Injector Out) will update to report the actual level established by the CNG. This represents the closest achievable value to the desired setting.
- 9 Noise ON/OFF (Carrier ON/OFF or Injector ON/OFF) Press Key 0 to toggle the Noise, Carrier or Injector signal ON/OFF at the CNG C+N Output. The Softkey 0 Display Window shows a Green background when the signal is ON and a Red background when the signal is OFF.
- 10 Increment Level Pressing the UP cursor key will increase the output level of the parameter by the amount currently specified in the Attenuator Step Size setting. Once the path attenuator has reached 0 dB this key will not have any effect.
- 11 Decrement Level Pressing the DOWN cursor key will decrease the output level of the parameter by the amount currently specified in the Attenuator Step Size setting. Once the path attenuator has reached its maximum value this key will not have any effect.

The CNG's current setup is reported via the collection of Softkey and Data Display Windows contained on the LCD Display.

GENERAL INFORMATION

General Information

Information on Safety Considerations, Description and Installation

This chapter provides general information pertaining to the Micronetics Carrier-to-Noise Generator (hereafter referred to as the CNG). Items covered here include:

- Safety Considerations
- Product Description
- Initial Inspection
- Installation & Preparation for Use

Safety Considerations

The CNG is a Class I instrument indicating that it has a protective earth terminal. That terminal must be connected to earth ground through a power source with a 3-wire ground receptacle.

Before installation or operation, check the CNG and review this manual for safety markings and instructions. Safety information for specific procedures is located at the appropriate places in the manual.

Do not install substitute parts or perform any unauthorized modification to the CNG. Return the CNG to Micronetics or an authorized Micronetics representative for service and repair to ensure that safety features are maintained.

Product Description

The Micronetics CNG-77xx series are precision Carrier-to-Noise Generators (CNG) designed for use in impairment test applications. The CNG features an internally filtered Additive White Gaussian Noise (AWGN) output incorporating a broad-band bandpass filter. The CNG allows the user to select from a series of operating modes for ratio or single signal use. The ratio modes enable the user to select a wide range of

highly stable carrier to noise ratios using either the internal noise source or an externally provided interferer signal (Injector Input Option). The single signal modes allow the user to operate the CNG as a Carrier or Interferer level controller, or a variable output Noise Generator.

Power level control and accuracy are maintained by an internal power meter. Calibration of the power meter is accomplished by using a built-in calibration reference source. The main display provides a graphical interface to all functions of the CNG, as well as status of all current settings. Function settings are controlled through Softkeys with direct keypad access or menu selections contained in the CNG pull-down menus.

Front panel control is typically performed through the Data Entry Keypad or optionally via the external keyboard. All CNG functions can also be controlled through the remote interface(s) is so equipped. The CNG functions and features are explained in full detail in the Front Panel Operation and Remote Interface Reference sections of this manual.

Initial Inspection

WARNING

To avoid hazardous electrical shock, do not perform electrical tests when there are signs of shipping damage to any portion of the outer enclosure (cover, panels, display, etc.)

The CNG is delivered in a single shipping carton containing the following items:

- Carrier-to-Noise Generator, 3U 19-inch rack-mountable enclosure
- Mini-Keyboard with AT-style connector
- AC Line Cord for standard 120 VAC USA operation
- 3.5-inch Floppy Disc containing backup copy of all system related software files
- Certificate of Calibration
- Performance Data Package
- This Operating Manual

Carefully inspect the shipping carton to and all items to ensure no damage occurred during shipment. Contact Micronetics, Inc or your local representative immediately if items are missing, or the CNG shows any evidence of damage.

Do not attempt to power up the unit if there is evidence of damage.

Installation & Preparation for Use

WARNING

This is a Safety Class I product. It is provided with a protective earth terminal. An uninterruptible safety earth ground must be provided from the mains power source to the supplied power cord set or CNG input wiring terminals.

When it is likely that the earth ground has been impaired, the CNG must be secured against unintended operation. If the CNG is to receive power via an external auto transformer, ensure that the transformer common terminal is connected to neutral (the grounded side of the mains supply).

WARNING

Before operating the CNG, the protective earth terminals must be connected to the protective conductor of the AC mains power cord. The mains plug shall be inserted only in a receptacle provided with a protective earth contact. This protection must not be compromised by the use of an extension cord lacking the protective grounding conductor..

Power Cord

The CNG is supplied with a standard 3-wire power cord that grounds the unit when connected to an appropriate AC power receptacle. Any power cord used in place of that provided must be a 3-wire type and provide proper grounding to the AC power receptacle.

RF Connections

The RF connectors provided will vary by CNG model. These connections will typically either be BNC Female, SMA Female or Type-N Female 50-ohm connectors. Some models may be configured for 75-ohm impedance or support both 50 and 75 ohms. Consult the specifications section of this manual for some details.

Remote Interface

The CNG may be equipped with one or more remote interfaces. If supplied with GPIB, the interface is located on the rear panel and uses a standard IEEE-488 24-pin connector. If supplied with RS-232, the interface is located on the rear panel and uses a standard 9-pin Female D-Sub connector. Consult the Remote Interface Reference section of this manual for full details on the use of these interfaces.

Operating Environment

The CNG is designed to operate in an environment within the following limits:

- Temperature: 0 to +55 °C
- Humidity: 95% relative MAX
- Altitude: 4570m (15,000 ft) MAX

Bench Operation

The standard CNG enclosure is equipped for bench-top or rack-mount installation. When in use on a bench-top, the front of the CNG can be raised off the bench surface by using the tilt-down legs contained as part of the enclosure's front mounting feet.

Care should be taken to position the CNG so that the airflow is not restricted at the cooling fan inlet. The protective dust filter should be removed and cleaned periodically to prevent airflow restriction and overheating.

Rack Mounting

The standard CNG enclosure comes equipped for mounting in a standard 19-inch equipment rack. The CNG requires a standard 3U height opening for mounting. The bench-top enclosure feet can be removed to ease in installation.

WARNING

The CNG requires adequate space beneath and behind the enclosure to ensure proper airflow for cooling. Stacking this CNG directly on top of another instrument in a rack will severely limit airflow for cooling and result in elevated internal operating temperatures. This may void the factory warranty.

When rack-mounting the CNG, ensure adequate space beneath and behind the instrument for proper airflow. The protective dust filter located over the cooling fan inlet should be removed and cleaned periodically to prevent airflow restriction and overheating.

Front Panel Operation

A detailed description of all the front panel controls

This chapter provides detailed information on the operation of the Micronetics Carrier-to-Noise Generator (CNG) through the front panel controls. Items covered here include:

- Main Display Layout
- Direct Softkey Controls
- Data Windows
- System Block Diagram
- Pull-down Menus
- External Keyboard Functions & Shortcuts
- Status Indicators

Main Display Layout

The main display area of the CNG front panel provides a graphical interface to the CNG functions as well as status of all the current parameter settings. This section is intended to acquaint the user with the various types of information provided on this display. Detailed information on the use of each Softkey or Menu item is then contained in the sections that follow.

The display area is partitioned into the following four (4) major sections as shown in Figure 3-1:

- 1 Main Menu-Bar The top level of each section of the CNG pull-down menus. The menu system is accessed using the F key on the front panel Data Entry keypad. See the section on Pull-down menus for full details.
- 2 Softkey and Data Display Windows This area contains information on the current set of direct access Softkeys as well as current parameter information contained in various data windows. See the sections on Direct Softkeys and Data Windows for full details.

- 3 System Block Diagram This central area provides a graphical view of the CNG RF block diagram. This diagram displays the current settings for path attenuators and RF switches.
- 4 Status Bar The lower portion of the display area contains the system status bar. This area shows the current settings for CNG Serial Number, State Register, System Impedance, Remote Interface and System Clock. See the section on Status indicators for full details.

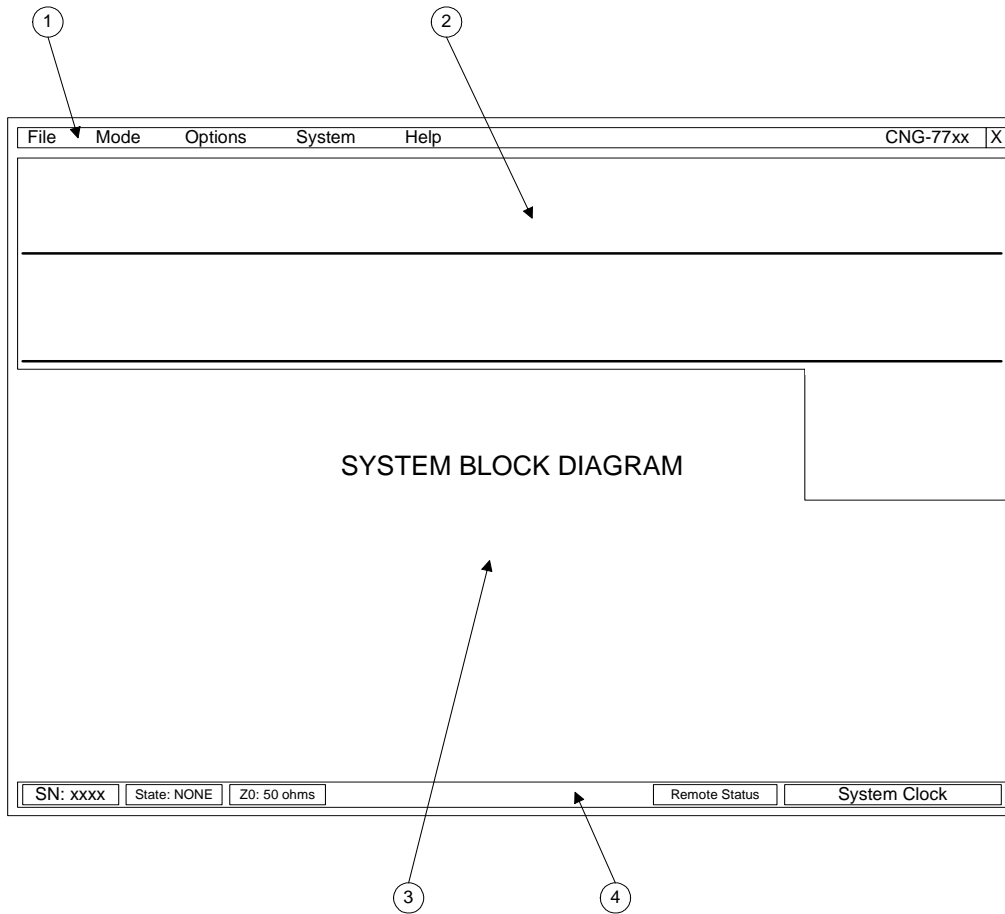

Figure 3-1: Main Display Layout illustrating the four major display sections for the CNG Front Panel Display

Direct Softkey Controls

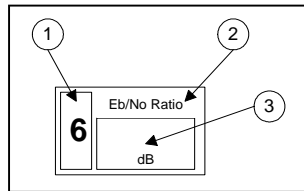

Figure 3-2: Direct Softkey Control 1

Functions that are more frequently accessed such as Set Ratio and Set Center Frequency are assigned to Direct Softkey Controls. Figure 3-2 depicts the first type of Direct Softkey Control denoted by these three (3) features:

- 1 Button Label
- 2 Function Label
- 3 Data Window

The function or parameter contained in the Function Label is accessed by pressing the Key noted in the Button Label using either the Data Entry keypad or the external keyboard. Pressing the associated Key will display a pull-down menu or Input Dialog box. Once the parameter is changed, the Data Window of the Direct Softkey Control will update to reflect the current setting.

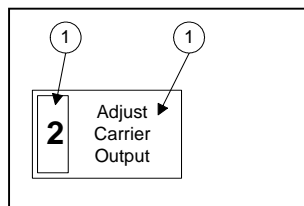

Figure 3-3: Direct Softkey Control 2

The second type of Direct Softkey Control is shown in Figure 3-3 and denoted by these two (2) features:

- 1 Button Label
- 2 Function Label

The function or parameter contained in the Function Label is accessed by pressing the Key noted in the Button Label.

In some cases, the system will provide an Input Dialog box for entry of a desired value for the parameter. The resultant setting of the parameter may then be displayed in a Data Window (as described below) elsewhere on the CNG Display.

Each of the Direct Softkey Controls is described in the following listing.

Key 1: Set Mode

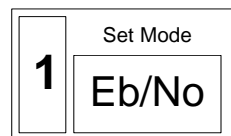

Softkey 1 allows the user to set the mode of operation for the CNG. Pressing Key 1 activates the Mode pull-down menu. Using the UP / DOWN cursor keys, move the highlighted bar to the mode desired. Press ENTER to complete the selection. A fully optioned CNG with Carrier path attenuator and Injector input will have the following modes to select from:

- C/N
- C/No
- Eb/No
- C/I
- Noise Only
- Carrier Only
- Injector Only

Once the selection is complete, the Direct Softkey 1 will display the mode selected and the CNG will configure the hardware to an initial state for this mode. Modes not

available due to specific CNG hardware configuration will be grayed out in the pull-down menu and cannot be selected from the menu's item list.

Key 2: Adjust Carrier Output



Softkey 2 allows the user to adjust the Carrier Output Level when operating in C/N, C/No, Eb/No or C/I modes with Carrier selected as the Constant or independent parameter. Prior to selecting this function, ensure that the Carrier Input signal is connected and present at the CNG rear panel Carrier

Input connector and the Carrier Frequency and DUT Bandwidth have been entered. Pressing Key 2 presents the user with an Input Dialog box. The dialog box will show the range of acceptable entries in the Entry Limits area in the upper right corner. The entry window will display the current setting for the Carrier Output in dBm. Enter the desired value and press the ENTER key to complete the entry. The CNG will adjust the Carrier path attenuator to the required setting to achieve the desired level. The Carrier @ Output Data Window will then update to reflect the actual Carrier Output level in dBm.

Key 2: Adjust Noise Density

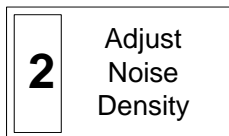

Softkey 2 allows the user to adjust the Noise Density Level when operating in C/N, C/No, or Eb/No modes with Noise selected as the Constant or independent parameter. Prior to selecting this function, ensure that the Center Frequency and DUT Bandwidth have been entered. Pressing Key 2 presents

the user with an Input Dialog box. The dialog box will show the range of acceptable entries in the Entry Limits area in the upper right corner. The entry window will display the current setting for the Noise Density in dBm/Hz. Enter the desired value and press the ENTER key to complete the entry. The CNG will adjust the Noise path attenuator to the required setting to achieve the desired level. The Noise Density Data Window will then update to reflect the actual Noise Density level in dBm/Hz.

Key 2: Adjust Injector Output (Injector Option Only)

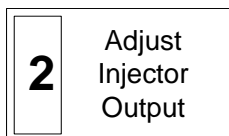

Softkey 2 allows the user to adjust the Injector Output Level when operating in the C/I mode with Injector selected as the Constant or independent parameter. Prior to selecting this function, ensure that the Injector Frequency and Inject Bandwidth have been entered. Pressing Key 2 presents the

user with an Input Dialog box. The dialog box will show the range of acceptable entries in the Entry Limits area in the upper right corner. The entry window will display the current setting for the Injector Output in dBm. Enter the desired value and press the ENTER key to complete the entry. The CNG will adjust the Noise/Injector path attenuator to the required setting to achieve the desired level. The Inject Power @ Output Data Window will then update to reflect the actual Injector Output level in dBm.

Key 2: Measure Injector Input (Injector Option Only)

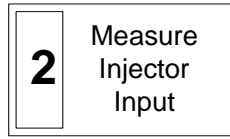

Softkey 2 allows the user to measure the Injector Signal Level when operating in the Injector Only mode. Prior to selecting this function, ensure that the Injector Frequency and Injector Bandwidth have been entered. Pressing Key 2 initiates the measurement process, provided that the CNG System Calibration has already been performed. The CNG will route the Injector signal to the internal Power Meter and determine the level of the Injector Signal at the CNG Injector Input Port. Once the measurement is complete, the CNG will update the Inject Power @ Output Data Window to reflect the actual Injector Output level in dBm. This function should be performed anytime that it is suspected that the input level of the Injector signal may have changed.

Key 3: Bit Rate

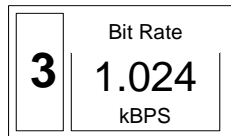

Softkey 3 allows the user to set the Carrier Bit Rate when operating in Eb/No mode. The CNG will use the Bit Rate setting together with the Carrier Output level to determine the Bit Energy, Eb. Pressing Key 3 presents the user with an Input Dialog box. The Bit Rate should be entered using an Engineering format nnn.nnnEnn Bits per Second (BPS). Use the UP cursor key to enter the “E” to identify the exponent. If using the external keyboard, either the E Key or UP arrow can be used to enter the “E”. Pressing the ENTER key will complete the entry and update the Direct Softkey Data Window.

Key 3: Injector Frequency (Injector Option Only)

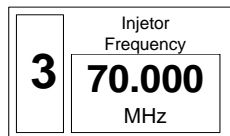

Softkey 3 allows the user to enter the Center Frequency of the Injector Signal when operating in C/I or Injector Only modes. Pressing Key 3 presents the user with an Input Dialog box. The dialog box will show the range of acceptable entries in the Entry Limits area in the upper right corner. The entry window will display the current setting for the Injector Center Frequency in the units indicated. Enter the desired value and press the ENTER key to complete the entry. The Direct Softkey Data Window will then update to reflect the Injector Center Frequency in the units displayed. The CNG will also update its path loss factors to reflect the average over the frequency range given by the Injector Center Frequency and Inject Bandwidth.

Key 4: Injector Bandwidth

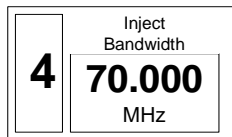

Softkey 4 allows the user to enter the Bandwidth of the Injector Signal when operating in C/I or Injector Only modes. Pressing Key 4 presents the user with an Input Dialog box. The dialog box will show the range of acceptable entries in the Entry Limits area in the upper right corner. The entry window will display the current setting for the Injector Bandwidth in the units indicated. Enter the desired value and press the ENTER key to complete the entry. The Direct Softkey Data Window will then update to reflect the Inject Bandwidth in the units displayed. The CNG will also update its path loss factors to reflect the average over the frequency range given by the Injector Center Frequency and Injector Bandwidth.

Key 5: Perform System CAL

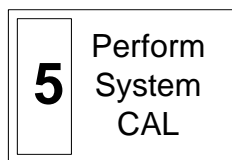

Softkey 5 will initiate the internal system calibration. Pressing Key 5 will present the user with a message box in the upper left of the display area asking the user to confirm the start of a system calibration. Press the ENTER key to confirm and start the calibration or press the ESC key to cancel.

The system calibration process consists of the following three (3) steps:

- 1 Power Meter zeroing
- 2 Power Meter reference calibration
- 3 Noise Source reference level measurement

The CNG will report the status of the process in a pop-up status window in the lower right corner of the display area. Once the calibration process completes successfully, Softkey 5 will stop alternating between red and green backgrounds and remain steady green. Should the system calibration fail, consult the Service section of this manual. The system calibration can be performed at any time the user feels it is required. It is recommended that the CNG be allowed to warm up for a minimum of 15 minutes prior to performing the first system calibration.

Key 6: Set Ratio

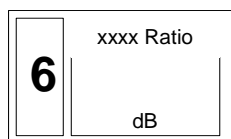

Softkey 6 allows the user to set the desired ratio when operating in C/N, C/No, Eb/No or C/I modes. The actual Function Label of this key will reflect the current CNG ratio mode. The Data Window will display units appropriate for the mode selected. Prior to selecting this function, the user should have selected and set all other CNG parameters such as Center Frequency, DUT Bandwidth and Constant Parameter Level. Pressing Key 6 presents the user with an Input Dialog box. The dialog box will show the range of acceptable entries in the Entry Limits area in the upper right corner. The entry window will display the current setting for the Ratio in the appropriate units for the mode. If blank, no ratio is currently set. Enter the desired value and press the ENTER key to complete the entry.

The CNG will adjust the Variable or dependent path attenuator to the required setting to achieve the desired ratio. The Direct Softkey Data Window will then update to reflect the actual Ratio set by the CNG.

Key 6: Set Noise Density

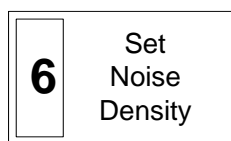

Softkey 6 allows the user to set the desired Noise Density level when operating in Noise Only mode. Prior to selecting this function, ensure that the Center Frequency and DUT Bandwidth have been entered. Pressing Key 6 presents the user with an Input Dialog box. The dialog box will show the range of acceptable entries in the Entry Limits area in the upper right corner. The entry window will display the current setting for the Noise Density in dBm/Hz. Enter the desired value and press the ENTER key to complete the entry. The CNG will adjust the Noise path attenuator to the required setting to achieve the desired level. The Noise Density Data Window will then update to reflect the actual Noise Density level in dBm/Hz.

Key 6: Set Carrier Output

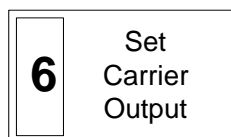

Softkey 6 allows the user to adjust the Carrier Output Level when operating in Carrier Only mode. Prior to selecting this function, ensure that the Carrier Input signal is connected and present at the CNG rear panel Carrier Input connector and the Carrier Frequency and DUT Bandwidth have been entered. Pressing Key 6 presents the user with an Input Dialog box. The dialog box will show the range of acceptable entries in the Entry Limits area in the upper right corner. The entry window will display the current setting for the Carrier Output in dBm. Enter the desired value and press the ENTER key to complete the entry. The CNG will adjust the Carrier path attenuator to the required setting to achieve the desired level. The Carrier @ Output Data Window will then update to reflect the actual Carrier Output level in dBm.

Key 6: Set Injector Output (Injector Option Only)

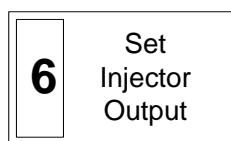

Softkey 6 allows the user to adjust the Injector Output Level when operating in the Injector Only mode. Prior to selecting this function, ensure that the Injector Input signal is connected and present at the CNG rear panel Injector Input connector and the Injector Frequency and Injector Bandwidth have been entered. Pressing Key 6 presents the user with an Input Dialog box. If not already known, the CNG will first measure the level of the Injector Input signal. The dialog box will show the range of acceptable entries in the Entry Limits area in the upper right corner. The entry window will display the current setting for the Injector Output in dBm. Enter the desired value and press the ENTER key to complete the entry. The CNG will adjust the Noise/Injector path attenuator to the required setting to achieve the desired level. The Inject Power @ Output Data Window will then update to reflect the actual Injector Output level in dBm.

Key 7: Modulation Factor

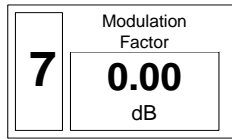

Softkey 7 allows the user to enter a Modulation Factor in dB when operating the C/N, C/No, Eb/No or C/I modes. This factor will be used to adjust the Carrier level prior to ratio calculations. It is intended to allow the user to adjust for modulation related factors associated with the Carrier Input

Signal, thus allowing the desired Ratio to be entered directly. Pressing Key 7 presents the user with an Input Dialog box. The dialog box will show the range of acceptable entries in the Entry Limits area in the upper right corner. The entry window will display the current setting for the Modulation Factor in dB. Enter the desired value and press the ENTER key to complete the entry. The CNG will update the Direct Softkey Data Window to reflect the value entered.

Key 7: Attenuator Step Size

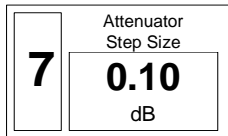

Softkey 7 allows the user to enter a value for attenuator step size when operating in Carrier Only, Noise Only or Injector Only modes. Pressing Key 7 presents the user with an Input Dialog box. The dialog box will show the range of acceptable entries in the Entry Limits area in the upper right corner. The

entry window will display the current setting for the Attenuator Step Size in dB. The entry must be an integral multiple of the physical attenuator's minimum step size. Enter the desired value and press the ENTER key to complete the entry. The CNG will adjust the entry if required to meet the integral requirement and then update the Direct Softkey Data Window to reflect the resultant value. Use of the UP / DOWN cursor keys will now result in the path attenuator decrementing or incrementing by this attenuator step size.

Key 8: Center Frequency

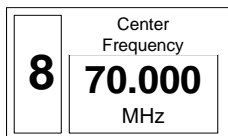

Softkey 8 allows the user to enter the system Center Frequency for all modes of operation. Pressing Key 8 presents the user with an Input Dialog box. The dialog box will show the range of acceptable entries in the Entry Limits area in the upper right corner. The entry window will display

the current setting for the Center Frequency in the units indicated. Enter the desired value and press the ENTER key to complete the entry. The Direct Softkey Data Window will then update to reflect the Center Frequency in the units displayed. The CNG will also update its Carrier path loss factors to reflect the average over the frequency range given by this Center Frequency and the DUT Bandwidth. In addition, the CNG will calculate the average Noise Density over the frequency range given by this Center Frequency and the DUT Bandwidth.

In order to maintain the best possible system accuracy, the CNG Center Frequency should be adjusted to reflect the frequency of the external Carrier Input being provided to the CNG.

Key 9: DUT Bandwidth

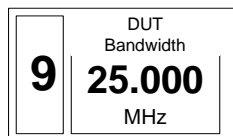

Softkey 9 allows the user to enter the DUT Bandwidth for all modes of operation. Pressing Key 9 presents the user with an Input Dialog box. The dialog box will show the range of acceptable entries in the Entry Limits area in the upper right corner. The entry window will display the current setting for the DUT Bandwidth in the units indicated. Enter the desired value and press the ENTER key to complete the entry. The Direct Softkey Data Window will then update to reflect the DUT Bandwidth in the units displayed. The CNG will also update its Carrier path loss factors to reflect the average over the frequency range given by the Center Frequency and this DUT Bandwidth. In addition, the CNG will calculate the average Noise Density over the frequency range given by the Center Frequency and this DUT Bandwidth.

NOTE It is important to realize that entering a value for DUT Bandwidth is important to the accuracy of the CNG's parameter setup. Even though the actual mode of operation currently selected may not need this DUT Bandwidth, the CNG still uses the information to calculate the system calibration factors that need to be applied for best possible system accuracy.

Key 0: Turn Noise ON / OFF

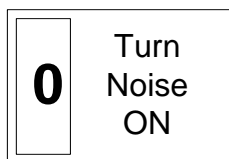

Softkey 0 allows the user to toggle the Noise Output ON or OFF when operating in the C/N, C/No, Eb/No and Noise Only modes. The Key 0 background and Function Label will alternate between the following two (2) conditions as the key is repeatedly pressed:

- 1 State: Noise OFF Background: RED Label: Turn Noise ON
- 2 State: Noise ON Background: GREEN Label: Turn Noise OFF

State 1 reflects the status of the Noise Output being in the OFF condition. Pressing Key 0 will turn ON the Noise Output and move the Direct Softkey to State 2 as described above. Pressing Key 0 again will return to State 1.

Key 0: Turn Carrier ON / OFF

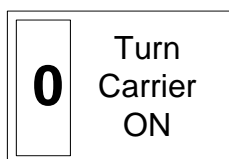

Softkey 0 allows the user to toggle the Carrier Output ON or OFF when operating in the Carrier Only mode. The Key 0 background and Function Label will alternate between the following two (2) conditions as the key is repeatedly pressed:

- 1 State: Carrier OFF Background: RED Label: Turn Carrier ON
- 2 State: Carrier ON Background: GREEN Label: Turn Carrier OFF

State 1 reflects the status of the Carrier Output being in the OFF condition. Pressing Key 0 will turn ON the Carrier Output and move the Direct Softkey to State 2 as described above. Pressing Key 0 again will return to State 1.

Key 0: Turn Injector ON / OFF (Injector Option Only)

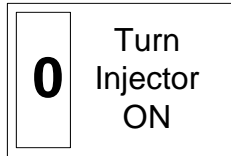

Softkey 0 allows the user to toggle the Injector Output ON or OFF when operating in the C/I or Injector Only modes. The Key 0 background and Function Label will alternate between the following two (2) conditions as the key is repeatedly pressed:

- 1 State: Injector OFF Background: RED Label: Turn Injector ON
- 2 State: Injector ON Background: GREEN Label: Turn Injector OFF

State 1 reflects the status of the Injector Output being in the OFF condition. Pressing Key 0 will turn ON the Injector Output and move the Direct Softkey to State 2 as described above. Pressing Key 0 again will return to State 1.

Data Windows

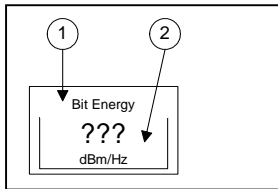

Figure 3-4: Data Window

The CNG employs Data Windows to report the current value or setting for parameters that are pertinent to the system setup. Figure 3-3 shows a typical Data Window which is denoted by these two (2) features:

- 1 Parameter Label
- 2 Parameter Data or Setting

The current setting or value of the item contained in the Parameter Label is reported in the Parameter Data area of the window. Data Windows are used to report parameters that the system may be measuring or altering directly or may be associated with a Type 2 Direct Softkey Control (as described above).

Each of the Data Windows is described in the following list.

Carrier @ Output

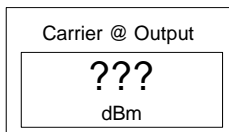

This Data Window reports the current level of the Carrier Signal at the CNG C+N Output Connector. The CNG display area depicts this data window for all operating modes except Noise Only and Injector Only. If the window displays ???, then the CNG has not yet completed the internal system

calibration. A blank data window indicates that the Carrier Output is in the OFF state (Carrier Only mode).

Noise Density

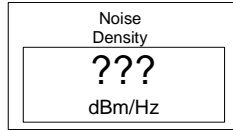

This Data Window reports the current level of Noise Density set for delivery at the C+N Output Connector. The CNG display area depicts this data window for all operating modes except C/I, Carrier Only and Injector Only. If the window displays ???, then the CNG has not yet completed the internal system calibration. Once the system is calibrated and the Noise Density is set, this Data Window will report the Noise Density level independent of the current state of the Noise ON / OFF control.

Carrier + Noise @ Output

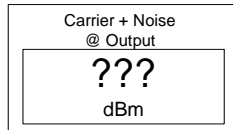

This Data Window reports the current level of the combined Carrier and Noise signals at the CNG C+N Output Connector. The CNG display area depicts this data window for C/N, C/No and Eb/No operating modes. If the window displays ???, then the CNG has not yet completed the internal system calibration. When the Noise Output is in the OFF state, this Data Window will report only the Carrier Output level.

Noise Power @ Output

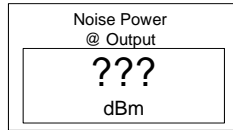

This Data Window reports the current level of the Noise Power at the CNG C+N Output Connector. The CNG display area depicts this data window in the C/N and Noise Only modes. If the window displays ???, then the CNG has not yet completed the internal system calibration. A blank data window indicates that the Noise Output is in the OFF state.

Inject Power @ Output (Injector Option Only)

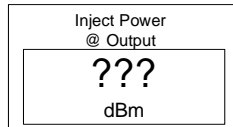

This Data Window reports the current level of the Injector Signal at the CNG C+N Output Connector. The CNG display area depicts this data window in the C/I and Injector Only modes. If the window displays ???, then the CNG has not yet completed the internal system calibration. A blank data window indicates that the Injector Output is in the OFF state.

Carrier + Injector @ Output (Injector Option Only)

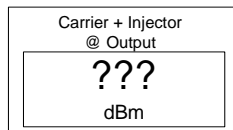

This Data Window reports the current level of the combined Carrier and Injector signals at the CNG C+N Output Connector. The CNG display area depicts this data window in the C/I mode. If the window displays ???, then the CNG has not yet completed the internal system calibration. When the Injector Output is in the OFF state, this Data Window will report only the Carrier Output level.

System Block Diagram

The System Block Diagram area contains a graphical representation of the RF hardware associated with this CNG model. The diagram will report the current setting of RF path attenuators and switches. These settings will change as the CNG is placed into different operating modes and as adjustments are made to establish the selected signal levels and ratios.

The Block Diagram together with the Direct Softkey Controls and Data Windows utilize a color-coding to group related functions, settings and block diagram sections.

BLUE signifies all Carrier-path related items

RED signifies all Noise-path related items

VIOLET signifies all Combined (Carrier+Noise)-path related items

LIGHT BLUE signifies all Power Sampling-related items

DARK GREEN identifies all System-related items

Normally all components in the Power Sampling section will display in a light blue color. If the CNG is not able to communicate and identify the internal power meter, the following indicators are presented in the CNG display area:

- POWER METER block is presently in a pale yellow color
- PERFORM SYSTEM CAL Softkey is presented in a gray color.

Pull-Down Menus

The CNG provides access to less frequently altered parameters and settings through a series of pull-down menus. The top most portion of each menu group is displayed in the Main Menu-Bar across the top portion of the Display area. When using the Data Entry keypad, the entire menu structure can be initially accessed by pressing the F key. This activates the first menu group, FILE. From there, the menu groups and items are navigated using the LEFT, RIGHT, UP and DOWN cursor keys.

The pull-down menus employ two (2) primary symbols to indicate whether an item is currently selected:

- √ - Indicates that an item is currently selected, enabled or ON. This item can be turned ON or OFF without impacting the status of other items within the menu group. Each time the item is selected it will toggle its state from ON to OFF or OFF to ON.
- - Indicates that an item is currently selected from a set of grouped items. Only one item from within the group can be selected or active at a time. Choosing an item from the set of items will disable (or un-select) all other items in the set.

Shortcut Keys

Several shortcut keys exist if the system is using the external keyboard. These keys provide direct access to the menu groups as follows:

- F key Access the File menu
- M key Access the Mode menu
- O key Access the Options menu
- S key Access the System menu
- H key Access the Help menu

The menu group will pull down from the main menu-bar directly and selections can then be made.

Several menu groups contain sub-groups of selections tied to a menu item. As the UP / DOWN cursor keys are used to move through menu selections, pausing on an item with a sub-group of selections will cause the sub-group list to pop-up automatically. Additionally, the sub-group can be displayed immediately if the RIGHT cursor key is used while the associated menu item is highlighted.

The following is a detailed list and description of all menu items organized by group. Note that some menu items may not be available in certain CNG models. These items

will be grayed out from the menu groups and skipped over as the menu groups or items are navigated.

FILE Menu

- **Save** The CNG has the ability to save its settings in any of up to 1000 registers. Selecting this menu item will present the user with an Input Dialog box. Enter a register number from 0 to 999 and press ENTER. The CNG will store the current settings into the register selected. The current register is indicated in the status bar area of the display. Register 0 (zero) is reserved for defining a power-up state for the CNG. This register, if present, will be automatically recalled upon initial power up of the CNG.
- **Recall** The CNG has the ability to recall any of up to 1000 registers that were previously saved. Upon recall, the CNG will reset all parameters and conditions to the settings at the time of the Save operation. One exception to this is that the Noise (or Injector) Output will be placed in the OFF state after the Recall is complete, regardless of its state at the time of Save. The current register is indicated in the status bar area of the display. Should an invalid register be selected (not yet stored), an error message will appear and the CNG will retain the current settings.
- **Delete** This item allows any previously defined register to be deleted from the CNG internal memory.
- **Exit** Selecting this will cause the CNG Operating System to prompt the user to confirm an Exit operation. Pressing the 1 (one) key will confirm the Exit and return the CNG system CPU to the DOS prompt. Simply cycle the CNG's AC power to restart the CNG Operating System. This operation is NOT required unless factory personnel have authorized specific troubleshooting or upgrade operations to be performed. Normally the CNG can simply be powered down by switching off the AC power at the rear panel.

MODE Menu

- **C/N** This places the CNG in the Carrier-to-Noise Power mode.
- **C/No** This places the CNG in the Carrier-to-Noise Density mode.
- **Eb/No** This places the CNG in the Bit Energy-to-Noise Density mode.
- **C/I** This places the CNG in the Carrier-to-Injector mode.
(Requires Injector Input option.)
- **No Only** This places the CNG in the Noise Only mode.

- Carr Only This places the CNG in the Carrier Only mode. (Requires Carrier path attenuator option.)
- Inj Only This places the CNG in the Injector Only mode. (Requires Injector Input option.)

OPTIONS Menu

- Show Clock Enables or disables the display of the System Clock in the lower right corner of the display area.
- Const: xxxx Selects the parameter to remain Constant or Independent in ratio modes. For CNG models with the Carrier path attenuator, the following choices exist:
 - CARRIER
 - NOISE (C/N, C/No, Eb/No)
 - TOTAL OUTPUT (not available at this time)
 - INJECTOR (C/I) (Requires Injector Input option)

For CNG models without the Carrier path attenuator, the CARRIER is the only choice available.
- Ratio Track (Optional on CNG models) When enabled, the CNG will adjust the Variable or dependent parameter automatically after the user makes a change to the Constant or independent parameter if a ratio had already been established by the user. For normal CNG operation (Ratio Track feature not present or disabled), any change in the Constant parameter's output level will invalidate any ratio that may have already been set. The CNG would indicate this by blanking out any value in the Set Ratio's Data Window. However, for a CNG equipped with this feature, Ratio Track functions as follows:
 1. Enable the Ratio Track option by selecting it from the Options Menu. A checkmark to the left of the item indicates it is selected or enabled.
 2. Adjust the Constant Parameter to the initial desired output level using Softkey 2.
 3. Set the desired Ratio using the Set Ratio Softkey, Key 6. A message entitled "RATIO LOCKED" in blue letters will appear in the upper left portion of the system block diagram area of the display. This signifies that the Ratio Track is enabled and now set.
 4. If the Constant Parameter output level is now altered using Softkey 2, the CNG will automatically adjust the Variable Parameter in response in an attempt to maintain

the Ratio set in step 3. If the CNG is not able to make the necessary adjustments to the Variable Parameter's output level, the message entitled "RATIO UNLOCKED" in red letters will appear in place of the RATIO LOCKED message in the upper left portion of the system block diagram area of the display.

5. Disabling the Ratio Track option will clear any message currently displayed.

- Signal Track

(Optional on CNG models equipped with Carrier Path Attenuator) When enabled, the CNG will attempt to maintain a constant Carrier Output level by adjusting the Carrier path attenuator in reaction to a detected change in Carrier Input Signal level. This feature is intended to address slow changes in Carrier Input level due to drift or long term stability. The Signal Track functions as follows:

1. Enable the Signal Track option by selecting it from the Options Menu. A checkmark to the left of the item indicates it is selected or enabled.
2. Select CARRIER as the Constant Parameter from the Options Menu under Const: xxx.
3. Adjust the Carrier Output to the desired level using Softkey 2. A message entitled "SIGNAL LOCKED" in blue letters will appear in the upper left portion of the system block diagram area of the CNG display. This signifies that the Signal Track is enabled and now set.
4. As the CNG detects changes in the Carrier Input level, it will use the Carrier path attenuator to adjust the CNG Carrier path loss to maintain a constant Carrier level at the CNG C+N Output. If the CNG is not able to adjust the attenuator enough, typically due to hardware limits, the message entitled "SIGNAL UNLOCKED" in red letters will appear in place of the SIGNAL LOCKED message in the upper left portion of the system block diagram area of the display.
5. The overall "holding range" of the Signal Track feature is determined by the boundaries of the Carrier path attenuator (0 dB and its maximum attenuation) relative to its setting after completion of step 3 above. For example, if the Carrier path attenuator gets set to 4.5 dB in response to step 3, then any decrease in the Carrier Input signal by more than 4.5 dB will result in an unlocked condition as the CNG will have reached the 0 dB attenuation boundary.

- Cal Monitor

(Optional on CNG models with 3200A power meters) When enabled, the CNG will monitor the reference calibration signal in an effort to determine when the system requires re-calibration due to thermal drift. Unlike the 3410A power meter, the 3200A model requires an external power reference used for calibration. A 50 MHz reference source is incorporated into the CNG hardware for use in calibrating the 3200A power meter. As such, this reference is then available as a signal to be measured to gauge system drift with the premise that the 50 MHz reference source itself remains at a stable consistent output level. The Cal Monitor feature works as follows:

1. Enable the Cal Monitor option by selecting it from the Options Menu. A checkmark to the left of the item indicates it is selected or enabled.
2. At the prescribed interval, typically 30 minutes, the CNG will perform a measurement of the reference signal. This interval can be adjusted through the Field Calibration Menu as described in Volume 3 of the CNG Manual set.
3. The measured level is then compared with the expected level for the CNG. If the difference between actual and expected exceeds the Cal Drift level, typically 0.20 dB, then the CNG will activate the flashing of the System Calibration Softkey. This indicates that the CNG has potentially drifted and degraded measurement accuracy. The setting for Cal Drift can be adjusted through the Field Calibration Menu as described in Volume 3 of the CNG Manual set.
4. If the CNG continually exhibits drift in the Cal Monitor measurement the CNG may require servicing at the Micronetics factory.

- Remote...

Selects the remote interface on CNG's configured with more than one remote interface. Choices are typically GPIB (IEEE-488) and RS-232. Only one remote interface can be active at any given time. The active interface is denoted in this Remote menu item as well as by the Remote Status window located along the bottom of the CNG display.

SYSTEM Menu

- View Factors Selecting this item presents an information box that contains a series of system-related factors such as path losses, average maximum noise density, noise reference error, etc. for the current CNG operating settings. Press ESC to clear the information from the main display area. This item can also be directly accessed by pressing the V key on the external keyboard.

- Set Clock... This item presents the sub-group items Set Date and Set Time. These allow the user to adjust the System Clock's date and time whenever necessary as described below.
 - Set Date This item allows the user to adjust the System Clock's date. The user is presented with an Input Dialog box and instructions to enter the desired date in a MM.DD.YYYY format. Pressing the ENTER key completes the entry and the System Clock display will then be updated accordingly.
 - Set Time This item allows the user to adjust the System Clock's time. The user is presented with an Input Dialog box and instructions to enter the desired time in a HH.MM.SS format. Pressing the ENTER key completes the entry and the System Clock display will then be updated accordingly.

- Set GPIB This item allows the user to configure the CNG's GPIB interface through the sub-group items described below.
 - Address: X This item displays the CNG's current setting for GPIB address (shown here as X). Selecting this item allows the user to set the GPIB Address to a value between 1 and 31. The user is presented with an Input Dialog box and the current setting in the entry field. The sub-group item will be updated after the user completes the new entry.
 - Talk/Listen This item selects the normal operating mode for the CNG on the GPIB interface: Talker/Listener. The Talker/Listener mode allows for two-way communications between the CNG and the System Controller. While in this mode, the CNG will respond to each command sent with either a confirmation, requested data or error message. For more information refer to Chapter 4 Remote Interface Reference in this manual.
 - Listen Only (currently not available) This mode will disable the CNG from sending command confirmations. The CNG will continue to provide requested data or error messages as required.

- Sys Cntrl (currently not available) This mode will allow the CNG to act as the System Controller on the GPIB interface. The CNG will then be able to control peripheral instruments such as Power Meter, Signal Generator, Spectrum Analyzer for automated calibration and characterization processes.
- Set RS-232 A future menu group to allow re-configuring of the Remote RS-232 interface as described below.
 - Baud: X This item displays the CNG's current setting for Baud Rate on the Remote RS-232 interface (shown here as X). Future releases of the CNG Operating System will allow the user to select from a series of available Baud Rates.
- Impedance (Only on CNG's equipped with Dual Impedance) Allows the user to set the System Impedance to 50 or 75 ohm operation. The current system impedance is indicated in the status bar of the display.
 - 50 Ohms Selecting this item sets the CNG's System Impedance to 50 ohms and activates the 50 ohm hardware connections. (50 Ohm or Dual Impedance Models ONLY.)
 - 75 Ohms Selecting this item sets the CNG's System Impedance to 75 ohms and activates the 75 ohm hardware connections. (75 ohm or Dual Impedance Models ONLY.)
- Set LANG... This item allows the user to select the language to be used for the Remote Interface. The options for language are as described below.
 - LEGACY The LEGACY option provides remote command support for the earlier versions of the CNG Operating System.
 - SCPI The SCPI option provides a new 488.2 and SCPI-like command structure. Details for using this command set are contained in Chapter 4 Remote Interface Reference of this manual.

HELP Menu

- About CNG... This item presents an information box containing data on Manufacturer, Model, Serial Number and Firmware Revision. Pressing the ESC key will clear this box from the display area.

REMOTE INTERFACE

-

Remote Interface Reference

A detailed discussion on the control of the CNG using the Remote Interface

This chapter provides detailed information on the operation of the Micronetics Carrier-to-Noise Generator (CNG) through the available remote interfaces. The standard CNG models come equipped with a GPIB IEEE-488 Parallel Interface for remote operation. Optionally, the CNG can be configured with a RS-232 Serial Interface in place of, or in addition to, the GPIB Interface. Items covered here include:

- GPIB (IEEE-488) Hardware Interface
- RS-232 (Serial) Hardware Interface
- General Programming Guidelines
- Remote Command Set – SCPI
- Legacy Command Cross Reference

GPIB (IEEE-488) Hardware Interface

The GPIB (General Purpose Interface Bus) connector on the rear panel connects the CNG to the computer and other GPIB devices. A GPIB system can be connected together in any configuration (linear, star, or both) as long as the following rules are observed:

- Each device on the GPIB (IEEE-488) interface must have a unique address. You can set the CNG address to any value between 1 and 31, although 31 is normally reserved for LISTEN ALWAYS configurations. The address is set to 1 (one) when the CNG is shipped from the factory. The GPIB address is displayed in the Set GPIB Sub-Menu located in the System Menu.
- ***You can set the GPIB address from the front panel only.***
- The address is stored in non-volatile memory and does not change when AC power has been off or after a power-on reset.

- Your computer's GPIB interface card has its own address. Be sure to avoid using the computer's address for any instrument on the interface bus. GPIB interface cards generally use address 21 (twenty-one).
- The total number of devices including the computer does not exceed 15.
- The total length of all the cables used is no more than 2 meters times the number of devices connected together, up to a maximum of 20 meters.
- Do not stack more than 3 (three) connector blocks together on any GPIB connector. Make sure that all connectors are fully seated and that the lock screws are firmly hand tightened.
- At least two thirds of all devices on the bus should be powered-on for proper operation.

GPIB Electrical Signal Configuration

The GPIB is an 8-bit parallel data transfer bus. In addition to the 8 data bits, the bus carries 3 (three) handshaking lines and 5 (five) GPIB specific management and control lines as described below. The remainder of the standard 24 pin connector is used for cable shield, signal grounds and returns. Figure 4-1 illustrates the GPIB connector and pin assignments.

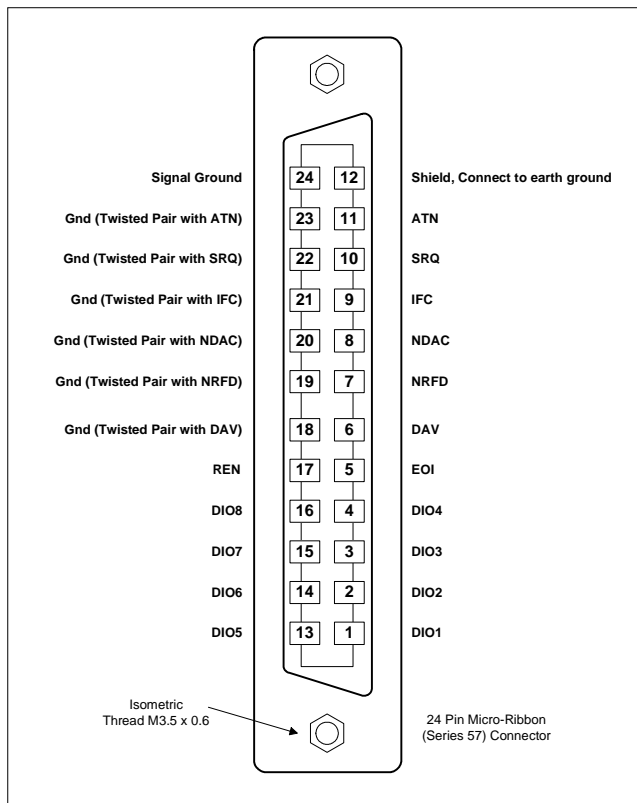

Figure 4-1: GPIB (IEEE-488) Interface Connector

Logic Levels – All logic levels are TTL compatible with the TRUE (1) state at 0 to +0.4 volts DC and the FALSE (0) state at +2.5 to +5.0 volts DC.

Data Lines – DIO1 through DIO8 are the data transfer bits. Most GPIB systems send 7-bit data and use the 8th bit as a parity or disregard it entirely.

Handshaking Lines – There are 3 (three) handshaking lines that control the data flow between devices:

- NRD (Not Ready For Data): this bit is used to indicate the readiness (or lack thereof) of a device to accept data.
- DAV (Data Valid): this bit is used to indicate to receiving devices that data has been placed on the bus and is available to read.
- NDAC (Not Data Accepted): this bit is asserted by the receiving device to indicate that data has been read and may now be removed from the bus.

System Management Lines – There are 5 (five) control lines used for system management by the devices:

- ATN (Attention): used by the System Controller to specify how data on the DIO lines is interpreted and which devices must respond to the data
- IFC (Interface Clear): used by the System Controller to place the entire system in a known quiescent (Cleared) state and to assert itself as Controller In Charge (CIC).
- SRQ (Service Request): used by a device on the bus to indicate the need for attention and requests an interrupt of the current event sequence.
- REN (Remote Enable): used by the System Controller in conjunction with other messages to place a device on the bus into either remote or local mode.
- EOI (End or Identify): used by Talkers to indicate the end of a message string, or is used by the System Controller to command a polling sequence.

Talkers, Listeners and Controllers

A GPIB device can be a Talker, Listener and/or Controller. As the name implies, a Talker sends data to one or more Listeners. A Listener accepts data from a Talker and a Controller manages the flow of information over the bus.

The Controller is in charge of all communications over the bus. The Controller's job is to make sure only one device tries to talk at a time, and to make sure the correct Listener(s) are receiving the data when the Talker talks. Each GPIB system has a single System Controller. The system Controller is ultimately in charge of the bus and is in control when the bus is powered up. There can be more than one Controller on the bus and the System Controller can pass active control to another Controller-capable device, though only one can be Controller-In-Charge at any given time. The computer in an automated test setup is usually designated as the System Controller.

RS-232 (Serial) Hardware Interface

The CNG can be optionally configured with an RS-232 Serial Interface for remote operation. This RS-232 interface may be in place of, or in addition to, the standard GPIB interface. The CNG can be connected to the RS-232 interface using the 9-pin (DB9) Female serial connector on the rear panel. The CNG is configured as a DCE (Data Communications Equipment) device. For all communications over the RS-232 interface, the CNG uses only software handshaking by responding to each command sent as detailed in the Command Reference section of this chapter. As such, the hardware control lines described below for reference are not utilized by the CNG.

RS-232 Electrical Signal Configuration

The RS-232 Interface is a serial data transfer bus. There are 2 (two) primary data lines, one for each direction of transfer, a signal ground, 2 (two) pairs of handshake / control lines and 2 (two) additional lines specific to modems. Figure 4-2 depicts the RS-232 Interface connector and pin assignments.

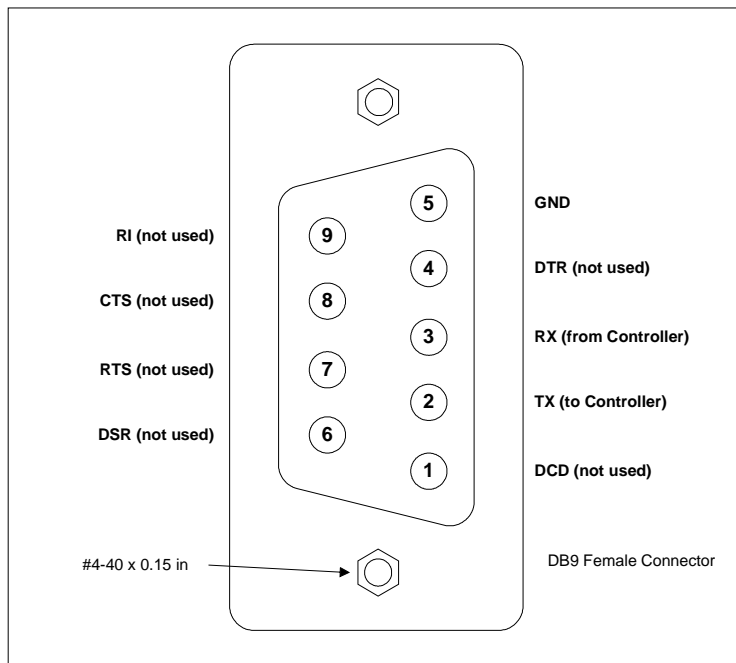

Figure 4-2: RS-232 Serial Interface Connector

Logic Levels - The logic states of the system are MARK/LOW signaled by -3 to $-15V$ (typically $-12V$) and represents a logical 1 and SPACE/HIGH is signaled by $+3$ to $+15V$ (typically $+12V$) and represents a logical 0.

Data Lines - TX and RX are the primary data communication lines and are labeled here from the perspective of the CNG. The CNG will transmit or send data to the Controller on the TX line. It will in turn receive data from the Controller on the RX line.

Handshaking Lines - There are 2 (two) pairs of lines that some systems use to coordinate the flow of data. These lines are not used by the CNG and are included here for information only.

- RTS (Ready To Send) / CTS (Clear To Send): The Controller (Data Terminal) will set the RTS to HIGH to initiate a data transmission. The receiving device (Data Set) will then respond by setting the CTS to HIGH signaling that it is ready to accept the data. Whenever the receiving device wants to stop/interrupt the communication, it drops CTS to LOW.
- DTR (Data Terminal Ready) / DSR (Data Set Ready): These lines are used to establish a connection at the very beginning where the Controller (Data Terminal) and the receiving device (Data Set) “shake hands” to ensure that they are both present and active. The Controller sets DTR to HIGH and the receiving device answers by setting DSR to HIGH.

Modem Lines - There are 2 (two) additional lines that are dedicated to use when the Data Set is a modem.

- DCD (Data Carrier Detect): The modem uses this line to indicate that it has detected the carrier of the modem on the other side of the phone line.
- RI (Ring Indicator): The modem uses this line to signal that the “phone rings”.

Signal Ground - The reference for all signals, data and control.

RS-232 Data Frame Format

A character frame consists of all the transmitted bits that make up a single character. The frame is defined to include the characters from the Start Bit to the last Stop Bit, inclusively. Within the frame, the following parameters define the configuration:

- Baud Rate: This is set to **19,200** at the factory (currently not adjustable).
- Parity: Typical are None, Odd or Even. The CNG is set to **NONE**.
- Data Bits: Typically 5, 7 or 8 bits. The CNG is set to **8 Data Bits**.
- Start Bits: **1 Bit**
- Stop Bits: Typically 1 or 2. The CNG is set to **1 Stop Bit**.

Connection to a Computer or Terminal

To connect the CNG to a computer or terminal, you must have the proper interface cable. Most computers and terminals are DTE (Data Terminal Equipment) devices. Since the CNG is configured as a DCE (Data Communications Equipment) device, a straight 9-pin interface cable can be used. This cable should have a DB9 Male connector on one end and a DB9 Female connector on the other end. At a minimum, pins 2, 3 and 5 must be wired from end to end providing the TX, RX and GND connections.

General Programming Guidelines

This section outlines some general guidelines that should be observed in order to successfully operate the CNG remotely.

Remote Configuration

If the CNG is equipped with both GPIB and RS-232 Remote Interfaces, then the desired interface must be selected from the Remote section of the Options Menu. The CNG display area will depict 1 (one) of the following Remote Status windows in the status bar in the lower portion of the display:

- GPIB Interface

Window Title: GPIB Status

Indicators:



R - Remote LED illuminated red whenever the CNG is in remote mode. All keys, except the ESC key, are disabled when the CNG is in Remote mode. Pressing the ESC key (internal keypad or external keyboard) will return the CNG to Local mode.

T - Talk LED illuminated green whenever the CNG is the Talker on the bus.

L - Listen LED illuminated green whenever the CNG is the Listener receiving data from the bus.

S - Status LED (currently not implemented)

- RS-232 Interface

Window Title: RS-232 Status

Indicators:

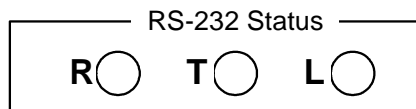

R - Remote LED illuminated red whenever the CNG is in remote mode. All keys, except the ESC key, are disabled when the CNG is in Remote mode. Pressing the ESC key (internal keypad or external keyboard) will return the CNG to Local mode.

T - Talk LED illuminated green whenever the CNG is the Talker on the bus.

L - Listen LED illuminated green whenever the CNG is the Listener receiving data from the bus.

Command Structure

The CNG's operating system is designed to provide a response to each remote command sent to the CNG whether using the GPIB or RS-232 interface. Hence, it is recommended that each string sent to the CNG contain only one remote command. The CNG will parse the command and respond in one of three ways:

- "OK" - this signals that the CNG has recognized the command and successfully performed the requested action.
- "ERRxx:" - this signals that the CNG has encountered a problem in either understanding the command or performing the requested action. See the section entitled Remote Error Codes for a complete list of the possible error codes.

- “data” – the specific data requested by a query command.

By sending a single command, action or query, the CNG is able to properly acknowledge and reply to the Controller. Some commands will take longer to process than others, so timeout settings on the Controller’s side should be reviewed to ensure that adequate time is allotted for the CNG to provide its response.

Command Language

The CNG can be configured to respond to either of two command sets:

1. SCPI – the newest and preferred command set that closely follows the standard SCPI (Standard Commands for Programmable Instruments) format and conventions. This provides a more structured and intuitive set of commands as compared to the LEGACY option.
2. LEGACY – the command set used by the older CNG operating system. This option is provided to allow use in automated systems that were created prior to the new SCPI command set being available. This option should not be used for development of new automated systems.

The Set LANG item in the System Menu is used to select the desired command set. All new remote application development should make use of the SCPI command set.

System Address

If controlling the CNG via the GPIB interface, the CNG device address must be set. The factory default address is 1 (one). The address can be set using the Set GPIB Sub-Menu under the System Menu.

Remote Command Set – SCPI

This section provides detail on each of the commands contained in the CNG's Remote Command Set for the SCPI language format. Please consult the Legacy Command Cross Reference if you are operating the CNG using the LEGACY language option.

SCPI Command Syntax

Throughout this manual, the following conventions are used for SCPI command syntax.

- Braces ({ }) enclose parameter choices within a command string.
- Triangle brackets (< >) indicate that you must substitute a value or code for the enclosed parameter.
- A vertical bar (|) separates one of two or more alternate parameters.

SCPI Command Terminators

A command string sent to the CNG *must* terminate with a <new line> character. A <carriage return> followed by a <new line> is also accepted.

488.2 Common Commands

The IEEE-488.2 standard defines a set of common commands that perform functions like reset, self-test and status operations. Common commands always begin with an asterisk (*), are four to five characters in length, and may include one or more parameters. The command keyword is separated from the first parameter by a *blank space*.

The CNG recognizes the following 488.2 common commands:

*RST

Action: Reset the CNG to the state defined by Register 0 (zero).

Response: "OK" or Error Code.

In order for this command to complete successfully, the user must have previously defined and saved a state into Register 0.

*IDN?

Action: Request the CNG's ID (identification) string

Response: "Micronetics, CNG-xxxx, SNxxxx, Vx.xx Month dd, yyyy"

The specific CNG Model Number, Serial Number and Operating System Version and Date of Release are included in this response string.

*RCL <n> n = 0 to 999

Action: Recall the CNG state settings from Register n.

Response: "OK" or Error Code

An error will result if an attempt is made to recall a register that does not exist.

*SAV <n> n = 0 to 999

Action: Save the current CNG state settings to Register n.

Response: "OK or Error Code

Unlike manual operation, no prompt for confirmation is provided prior to overwriting a previously defined Register.

System Level Commands

The following group of commands is related to system level actions such as calibration and system clock.

SYST:CAL {MTR | NOISE | ALL}

Action: Perform a system calibration for Power Meter Only (MTR), Noise Reference Only (NOISE) or both (ALL).

Response: "OK" or Error Code

This performs the equivalent of Softkey 5: System Calibration when issued with the ALL option. In addition, the user has the flexibility under remote operation to perform separate updates of the power meter and noise reference portions of the calibration. In order to perform the NOISE option, the CNG must have first successfully completed the power meter portion of the calibration (MTR option).

SYST:CAL?

Action: Requests the current state of the CNG system calibration.

Response: "CAL: n" where n = 0 if no calibration exists
 1 if completed power meter only
 2 if completed all portions

NOTE: If "?" is appended to the response, then the Cal Monitor option is enabled and has detected calibration drift that exceeds the current specified threshold (Cal Button flashing).

SYST:CAL:DRIFT <x.xx>

Action: Sets the value for allowed calibration drift in x.xx dB.

Response: "OK" or Error Code

This parameter is used by the CNG as the threshold for allowed drift when the Cal Monitor option is enabled. This applies only to a CNG with the 3200A power meter.

SYST:CAL:DRIFT?

Action: Requests the current value for the calibration drift threshold.

Response: "CALDRIFT: x.xxx" where value is in dB

SYST:CAL:MONTIME <n> n = 0 to 1440

Action: Sets the calibration check interval time in minutes.

Response: "OK" or Error Code

This parameter determines how frequently the system checks for calibration drift when the Cal Monitor option is enabled. This only applies to a CNG with the 3200A power meter.

SYST:CAL:MONTIME?

Action: Requests the current value for the calibration check interval.

Response: "CAL MON TIME: n" where n is in minutes

SYST:CLK:DISP {ON | OFF}

Action: Sets the state of the system clock display option.
Response: "OK" or Error Code

This will turn ON or OFF the display of the system clock in the lower right corner of the display.

SYST:CLK:DISP?

Action: Request the current state of the system clock display.
Response: "ON" or "OFF"

SYST:CLK:DATE <yyyy,mm,dd>

where yyyy = Year mm = Month (01 to 12) dd = Day (01 to 31)

Action: Sets the system clock's Date.
Response: "OK" or Error Code

This will set the date portion of the CNG system clock to mm/dd/yyyy. The year, month and date fields are separated by commas.

SYST:CLK:DATE?

Action: Requests the current setting for the system clock's Date.
Response: "mm/dd/yyyy"
where mm = Month dd = Day yyyy = Year

SYST:CLK:TIME <hh,mm,ss>

where hh = Hours (0 to 23) mm = Minutes (0 to 59) ss = Seconds (0 to 59)

Action: Sets the system clock's Time.
Response: "OK" or Error Code

This will set the time portion of the CNG system clock to hh:mm:ss using a 24 hour format.

SYST:CLK:TIME?

Action: Requests the current setting for the system clock's Time.
Response: "hh:mm:ss"
where hh = Hour mm = Minutes ss = Seconds

SYST:IMPED {50 | 75}

Action: Set the System Impedance to 50 or 75 ohms.
Response: "OK" or Error Code

This command sets the System Impedance in a CNG configured with the Dual Impedance Option. All other CNG configurations will return an error for this command.

SYST:IMPED?

Action: Requests the current state of the System Impedance
Response: "IMP: 50" or "IMP: 75"

SYST:LANG {SCPI | LEGACY}

Action: Sets the System Language to SCPI or LEGACY mode

Response: "SCPI" or "LEGACY"

Normally this command would be used to move from SCPI mode to LEGACY mode. Issuing this command when already in LEGACY mode would potentially generate a syntax error.

SYST:LANG?

Action: Request the current setting for System Language

Response: "SCPI" or "LEGACY"

If this command generates an error, then the CNG is likely to be in LEGACY mode.

SYST:SERN?

Action: Request the Serial Number of this CNG

Response: "xxxx" where xxxx = the unique serial number of this CNG.

Mode Commands

The follow group of commands defines the mode of operation for the CNG.

MODE:RAT {CN | CNO | EBNO | CI | NO | CO | IO}

Action: Selects the mode of operation for the CNG where
CN = C/N mode
CNO = C/No mode
EBNO = Eb/No mode
CI = C/I mode (Injector Input Option only)
NO = Noise Only mode
CO = Carrier Only Mode (Carrier Path Attenuator required)
IO = Injector Only mode (Injector Input Option only)

Response: "OK" or Error Code

This command configures the CNG for the fundamental mode of operation desired.

MODE:RAT?

Action: Requests the current mode of operation

Response: "MODE: mmm"
where mmm = "CN" for C/N mode
"CNO" for C/No mode
"EBNO" for Eb/No mode
"CI" for C/I mode
"NO" for Noise Only mode
"CO" for Carrier Only mode
"IO" for Injector Only mode

MODE:CONST {CARR | NOISE | OUTP | INJECT}

Action: Sets the Constant Parameter for ratio operations

Response: "OK" or Error Code

This command determines which parameter will be held constant in establishing ratios. An Error Code will result if this command is issued when the CNG is not in a Ratio type mode of operation.

MODE:CONST?

Action: Requests the current setting for the constant parameter.

Response: "CONSTANT: mmm"
where mmm = "CARRIER" for Constant Carrier Level
"NOISE" for Constant Noise Level
"INJECT" for Constant Injector Level
"TOTAL" for Constant Total Combined Level

Ratio Commands

The follow group of commands relate to setting a ratio on the CNG.

RAT:SET <x.xx>

Action: Sets the desired ratio for the current mode selected to x.xx
Units are dB-Hz for C/No and dB for all other ratio modes

Response: "OK" or Error Code

This command instructs the CNG to adjust the Variable Parameter to achieve the desired ratio. An error will occur if the CNG is not calibrated, not in a ratio mode or the ratio is out of the achievable range.

RAT:SET?

Action: Requests the value of the current Ratio that is set

Response: "x.xxx" or "NONE" or Error Code
Results are in dB-Hz for C/No mode and dB for all other ratio modes.

This command will result in an error if the current mode of operation is not a ratio mode. The "NONE" response will occur if a valid ratio does not exist.

RAT:RANG?

Action: Requests the available range of ratios that can be set.

Response: "x.xxx / y.yyy" or Error Code
Results are in dB-Hz for C/No mode and dB for all other ratio modes where x.xxx is the minimum value and y.yyy is the maximum value.

This command will cause the CNG to examine the current settings of the Constant Parameter and the available range of the Variable Parameter. From this the CNG will determine the range of values that can be set for a ratio. This command will result in an error if the current mode of operation is not a ratio mode.

Carrier Path Commands

The following group of commands pertains to the carrier signal path.

CARR:FREQ <xxx>

Action: Sets the Center Frequency to reflect the frequency of the Carrier Signal.
Entry is made in units of Hz.

Response: "OK" or Error Code

This command tells the CNG the center frequency of the Carrier Input Signal. This information is then used to apply the proper carrier path calibration factors.

CARR:FREQ?

Action: Requests the current setting of Center Frequency.

Response: "x.xxx" in Hz

CARR:FREQ:RANG?

Action: Requests the available range for setting Center Frequency.

Response: "x.xxx / y.yyy" in Hz where x.xxx is the minimum value and y.yyy is the maximum value.

CARR:POW <x.xx>

Action: Sets the Carrier Output level to x.xx dBm

Response: "OK" or Error Code

This command is available only in modes of operation where the carrier signal is active and is set to be the Constant Parameter. Any other conditions will result in an error code.

CARR:POW?

Action: Requests the current value of the Carrier Output level in dBm

Response: "x.xxx" in dBm or Error Code

This command will result in an error code if the carrier signal is not active in the current mode of operation.

CARR:POW:INP?

Action: Requests the current value of the Carrier Input level in dBm

Request: "x.xxx" in dBm

This command will result in an error code if the carrier signal is not active in the current mode of operation.

CARR:POW:RANG?

Action: Requests the available range of Carrier Output levels that can be set.

Response: "x.xxx / y.yyy" in dBm where x.xxx is the minimum value and y.yyy is the maximum value.

CARR:POW:STEP <x.xx>

Action: Sets the value for the Carrier level step increment in dB

Response: "OK" or Error Code

This command is used in Carrier Only mode. If the CNG is currently in another mode of operation, then an error code will be generated.

CARR:POW:STEP?

Action: Requests the current setting of the carrier level step increment in dB

Response: "x.xxx" in dB

This command results in an error if the current mode of operation is not Carrier Only.

CARR:POW INC

Action: Increases the Carrier Output level by the current step increment in dB

Response: "OK" or Error Code

The CNG will attempt to adjust the Carrier Output level by the current step increment. If the CNG is not in the Carrier Only mode of operation, an error will result.

CARR:POW DEC

Action: Decreases the Carrier Output level by the current step increment in dB

Response: "OK" or Error Code

The CNG will attempt to adjust the Carrier Output level by the current step increment. If the CNG is not in the Carrier Only mode of operation, an error will result.

CARR:STAT {ON | OFF}

Action: Set the state of the Carrier Output to ON or OFF (full attenuation).

Response: "OK" or Error Code

This command will allow the carrier output to be turned ON or OFF. An error will result if the CNG is not in a mode of operation that involves the carrier signal.

CARR:STAT?

Action: Requests the current state of the Carrier Output.

Response: "ON" or "OFF"

CARR:BITR <xxx>

Action: Set the value for Bit Rate to xxx Bits Per Second.

Response: "OK" or Error Code

This command accepts entries of xxx in floating point or scientific notation. An error will occur if the CNG is not in Eb/No mode of operation.

CARR:BITR?

Action: Requests the current value for Bit Rate.

Response: "xxxEnn" in Bits Per Second

This command will produce an error if the CNG is not in Eb/No mode.

CARR:BITENG?

Action: Requests the current value for Bit Energy.

Response: "x.xxx" in dBm/Hz

This command will produce an error if the CNG is not in Eb/No mode.

CARR:MODF <xxx>

Action: Sets the value for Modulation Factor to xxx dB

Response: "OK" or Error Code

CARR:MODF?

Action: Requests the current setting for Modulation Factor.

Response: "x.xxx" in dB

Carrier Path Factory Commands

The following group of commands related to the Carrier path is intended for factory use only. General use is NOT recommended.

CARR:ATTEN:SET <xxx>

Action: Set the Carrier Attenuator to xxx dB

Response: "OK" or Error Code

CARR:ATTEN:SET?

Action: Requests the current setting of the Carrier Attenuator

Response: "x.xxx" in dB

CARR:ATTEN:RANG?

Action: Requests the available range of settings for the Carrier Attenuator

Response: "x.xxx / y.yyy" in dB where x.xxx is the minimum value and y.yyy is the maximum value.

CARR:ATTEN:STATE <n> n = integral value

Action: Set the physical state of the Carrier Attenuator.

Response: "OK" or Error Code

CARR:ATTEN:STATE?

Action: Requests the current state of the Carrier Attenuator

Response: "n" the integral state for example "345" for 34.5 dB

CARR:ATTEN:STATE:RANG?

Action: Requests the range of available states for the Carrier Attenuator

Response: "m / n" where m is the minimum and n is the maximum state

CARR:RAW?

Action: Requests the current Raw Carrier reading from the power meter

Response: "x.xxx" in dBm

Noise Path Commands

The following group of commands pertains to the noise path of the CNG.

NOISE:POW <x.xx>

Action: Set the desired Noise Output Power in dBm

Response: "OK" or Error Code

This command will adjust the Noise Output based on the current setting for DUT Bandwidth. This command is available only in modes of operation where the noise signal is active and is set to be the Constant Parameter. Any other conditions will result in an error code.

NOISE:POW?

Action: Requests the current setting for Noise Power.

Response: "x.xxx" in dBm

NOISE:POW:RANG?

Action: Requests the available range for setting Noise Power

Response: "x.xxx / y.yyy" in dBm where x.xxx is the minimum value and y.yyy is the maximum value.

NOISE:AVG?

Action: Requests the current Maximum Average Noise Density

Response: "x.xxx" in dBm/Hz

NOISE:BW <xxx>

Action: Set the DUT Noise Bandwidth to xxx Hz

Response: "OK" or Error Code

NOISE:BW?

Action: Requests the current setting for DUT Noise Bandwidth

Response: "x.xxx" in Hz

NOISE:BW:RANG?

Action: Requests the available range of settings for DUT Noise Bandwidth

Response: "x.xxx / y.yyy" in Hz where x.xxx is the minimum value and y.yyy is the maximum value.

NOISE:DENS <x.xx>

Action: Sets the Noise Density level to x.xx dBm/Hz

Response: "OK" or Error Code

This command is available only in modes of operation where the noise signal is active and is set to be the Constant Parameter. Any other conditions will result in an error code.

NOISE:DENS?

Action: Requests the current setting for Noise Density

Response: "x.xxx" in dBm/Hz

NOISE:DENS:RANG?

Action: Requests the available range of settings for Noise Density

Response: "x.xxx / y.yyy" in dBm/Hz where x.xxx is the minimum value and y.yyy is the maximum value.

NOISE:DENS:STEP <x.xx>

Action: Sets the value for Noise Density step increment to x.xx dB

Response: "OK" or Error Code

NOISE:DENS:STEP?

Action: Requests the current setting for Noise Density step increment

Response: "x.xxx" in dB

NOISE:DENS INC

Action: Increase the Noise Density level by the current step increment

Response: "OK" or Error Code

NOISE:DENS DEC

Action: Decrease the Noise Density level by the current step increment

Response: "OK" or Error Code

NOISE:SOUR {NOISE | INJECT}

Action: Set the Noise Input to internal noise or external injector

Response: "OK" or Error Code

This command will produce an error if INJECT is selected for a CNG without the Injector Input Option.

NOISE:SOUR?

Action: Requests the current setting for Noise Source Input

Response: "NOISE" or "INJECT"

NOISE:STAT {ON | OFF}

Action: Sets the state of the Noise Output to ON or OFF

Response: "OK" or Error Code

NOISE:STAT?

Action: Requests the current state of the Noise Output

Response: "ON" or "OFF"

NOISE:NEBW?

Action: Requests the CNG's Noise Equivalent Bandwidth

Response: "x.xxx" in kHz

NOISE:REF?

Action: Requests the CNG's Noise Reference level
 Response: "x.xxx" in dBm

NOISE:ERROR?

Action: Requests the CNG's Noise Reference Error
 Response: "x.xxx" in dB

This command responds with the error in dB that resulted from the last system calibration of the noise path.

Noise Path Factory Commands

The following group of commands related to the Noise path is intended for factory use only. General use is NOT recommended.

NOISE:ATTEN:SET <xxx>

Action: Set the Noise Attenuator to xxx dB
 Response: "OK" or Error Code

NOISE:ATTEN:SET?

Action: Requests the current setting of the Noise Attenuator
 Response: "x.xxx" in dB

NOISE:ATTEN:RANG?

Action: Requests the available range of settings for the Noise Attenuator
 Response: "x.xxx / y.yyy" in dB where x.xxx is the minimum value and y.yyy is the maximum value.

NOISE:ATTEN:STATE <n> n = integral value

Action: Set the physical state of the Noise Attenuator.
 Response: "OK" or Error Code

NOISE:ATTEN:STATE?

Action: Requests the current state of the Noise Attenuator
 Response: "n" the integral state for example "345" for 34.5 dB

NOISE:ATTEN:STATE:RANG?

Action: Requests the range of available states for the NoiseAttenuator
 Response: "m / n" where m is the minimum and n is the maximum state.

Injector Path Commands

The following group of commands pertains to the Injector path of a CNG that is equipped with the Injector Input Option.

INJECT:FREQ <xxx>

Action: Sets the Injector Center Frequency to reflect the frequency of the Injector Signal. Entry is made in units of Hz.

Response: "OK" or Error Code

This command tells the CNG the center frequency of the Injector Input Signal. This information is then used to apply the proper injector path calibration factors.

INJECT:FREQ?

Action: Requests the current setting of Injector Center Frequency.

Response: "x.xxx" in Hz

INJECT:FREQ:RANG?

Action: Requests the available range for setting Injector Center Frequency.

Response: "x.xxx / y.yyy" in Hz where x.xxx is the minimum value and y.yyy is the maximum value.

INJECT:BW <xxx>

Action: Set the Injector Noise Bandwidth to xxx Hz

Response: "OK" or Error Code

INJECT:BW?

Action: Requests the current setting for Injector Noise Bandwidth

Response: "x.xxx" in Hz

INJECT:BW:RANG?

Action: Requests the available range of settings for Injector Noise Bandwidth

Response: "x.xxx / y.yyy" in Hz where x.xxx is the minimum value and y.yyy is the maximum value.

Options Menu Commands

The following group of commands is related to features contained in the Options Menu.

OPT:SIGTRACK {ON | OFF}

Action: Enables or disables the Carrier Signal Tracking option.

Response: "OK" or Error Code

Once enabled with this command, Signal Tracking will be activated when the Carrier Output level is set using the CARR:POW command.

OPT:SIGTRACK?

Action: Requests the current state of the Signal Tracking option.

Response: "ON" or "OFF"

OPT:TRACK {ON | OFF}

Action: Enables or disables the Ratio Tracking option.

Response: "OK" or Error Code

Once enabled with this command, Ratio Tracking will be activated when a Ratio is set using the RAT:SET command.

OPT:TRACK?

Action: Requests the current state of the Ratio Tracking option.

Response: "OK" or Error Code

OPT:CALMON {ON | OFF}

Action: Enable or disable the Calibration Monitoring option

Response: "OK" or Error Code

This command will result in an error if the CNG is not configured with a 3200A power meter. Once enabled, the CNG will then perform a periodic measurement of the reference source to determine if the system calibration has drifted.

OPT:CALMON?

Action: Requests the current state of the Calibration Monitoring option

Response: "ON" or "OFF"

Combined Output Commands

The following group of commands is related to the Combined Output path.

OUTP:STAT {ON | OFF}

Action: Sets the current state of the Combined Output to ON or OFF

Response: "OK" or Error Code

This command is only available for use a CNG configured with a combined output path switch. All other CNG configurations will result in an error code.

OUTP:STAT?

Action: Requests the current state of the Combined Output

Response: "ON" or "OFF"

This command is only available for use a CNG configured with a combined output path switch. All other CNG configurations will result in an error code.

OUTP:POW <x.xx>

Action: Sets the desired Total Combined Output level to x.xx dBm

Response: "OK" or Error Code

NOTE: This feature is currently not available.

OUTP:POW?

Action: Requests the current setting for Total Combined Output level

Response: "x.xxx" in dBm

NOTE: This feature is currently not available.

Power Sampling Factory Commands

The following group of commands related to the Power Meter sampling paths is intended for factory use only. General use is NOT recommended.

MTRPATH:STAT {TERM | CARRIER | NOISE}

Action: Set the state of the power sampling RF switches

Response: "OK" or Error Code

MTRPATH:STAT?

Action: Requests the current state of the power sampling RF switches

Response: "TERM" or "CARRIER" or "NOISE"

GPIO Only Commands

The following commands are only available when controlling the CNG with the GPIO Interface.

GTL

Action: Return the CNG to Local mode.

Response: none

Remote Error Codes

The following is a list of Error Codes that may occur during remote operation of the CNG. The entire string, error code and description, will be sent out by the CNG.

ERR1: PARAMETER OUT OF RANGE

The CNG has detected that a desired value provided in a command is outside of the acceptable or achievable range of values for that parameter given the current settings of the CNG.

ERR2: COMMAND SYNTAX ERROR

The CNG does not recognize the command string as provided. Check the string for proper use of spaces, colons and command spelling.

ERR3: INVALID COMMAND FOR SETTINGS

The command issued cannot be processed under the current CNG settings.

ERR4: COMMAND FAILED TO COMPLETE

The command issued was not able to complete its task properly or completely.

ERR5: BAD PARAMETER IN COMMAND

The command contains a parameter that is outside of the options available.

ERR6: COMMAND NOT AVAILABLE IN THIS MODE

This command cannot be processed while in the current mode of operation. For example, attempting to set Bit Rate when in a mode other than Eb/No.

ERR7: COMMAND ABORTED

The command was aborted per user request or due to hardware problems.

ERR8: SYSTEM NOT CALIBRATED

The command issued requires that the CNG be calibrated prior to its execution.

ERR9: SYSTEM CALIBRATION FAILED

The CNG was not able to complete the system calibration.

ERR10: CARRIER POWER NOT MEASURED

This command requires that carrier power level be measured prior to its execution.

ERR100: UNKNOWN ERROR

Legacy Command Cross Reference

This section provides a cross reference from LEGACY language commands to the new SCPI command set. In addition, all query type commands also denote the response that is issued by the CNG when in LEGACY mode. These responses differ in most cases from those obtained from the CNG when operating in SCPI mode.

Not all SCPI commands have a corresponding LEGACY command as several new features and functions have been added to the CNG Operating System with the new major release. Users may find that it provides great benefit to operate the CNG in the SCPI mode.

LEGACY Cmd	SCPI Equivalent	Legacy Response
\$QID;	*IDN?	"CNG-xxxxx {xxxx} x.xx mm/dd/yyyy"
\$SCFxxx.x;	CARR:FREQ <x.xx>	Same as SCPI
\$QCFR;	CARR:FREQ:RANG?	"CFR: x.xxx/y.yyy"
\$SCARxxx.x;	CARR:POW <x.xx>	Same as SCPI
\$QCIN;	CARR:POW:INP?	"CINP: x.xx"
\$QCAR;	CARR:POW?	"CAR: x.xx"
\$QCPR;	CARR:POW:RANG?	"CPR: x.xx/y.yy"
\$DSW10;	CARR:STAT OFF	Same as SCPI
\$DSW11;	CARR:STAT ON	Same as SCPI
\$SEBRxxx.x;	CARR:BITR <xxx>	Same as SCPI
\$QEBR;	CARR:BITR?	"EBR: nnnnn"
\$QEBP?	CARR:BITENG?	"EBP: x.xx"
\$CNM;	MODE:RAT CN	Same as SCPI
\$CNOM;	MODE:RAT CNO	Same as SCPI
\$CEBM;	MODE:RAT EBNO	Same as SCPI
\$CIM;	MODE:RAT CI	Same as SCPI
\$CNOZ;	MODE:RAT NO	Same as SCPI
\$CCAR;	MODE:RAT CO	Same as SCPI
\$QMOD;	MODE:RAT?	"MOD: nnn"
\$QNPOW;	NOISE:POW?	"NPOW: x.xx"
\$QAVD;	NOISE:AVG?	"AD: x.xxx"
\$SBWxxx.x;	NOISE:BW <x.xx>	Same as SCPI
\$QBNR;	NOISE:BW:RANG?	"BNR: 0.001 / x.xxx"
\$SSNOZxxx.x;	NOISE:DENS <x.xx>	Same as SCPI
\$QNOZ;	NOISE:DENS?	"NOZ: x.xx"
\$QNDR;	NOISE:DENS:RANG?	"NDL: x.xxx/y.yyy"
\$DSW30;	NOISE:STAT OFF	Same as SCPI
\$DSW31;	NOISE:STAT ON	Same as SCPI
\$QNEBW;	NOISE:NEBW?	"NEBW: x.xxx"

LEGACY Cmd	SCPI Equivalent	Legacy Response
\$CNRxxx.x;	RAT:SET <x.xx>	Same as SCPI
\$QRAT;	RAT:SET?	“C/N: x.xx” or “C/No: x.xx” etc.
\$QRAN;	RAT:RANG?	“RAN: x.xx/y.yy”
\$CAL;	SYST:CAL ALL	Same as SCPI
\$SIMPxx;	SYST:IMPED xx	Same as SCPI (xx = 50 or 75)
\$QIMP;	SYST:IMPED?	“IMP: 50” or “IMP: 75”
\$LANG <option>;	SYST:LANG <option>	Same as SCPI (option = SCPI or LEGACY)
\$QLANG;	SYST:LANG;	Same as SCPI
\$QSN;	SYST:SERN?	Same as SCPI
\$DATTN1xxx.x;	CARR:ATTEN:SET	Same as SCPI
\$QDATN1;	CARR:ATTEN:SET?	Same as SCPI
\$QPOW;	CARR:RAW?	“POW: x.xx”
\$DATTN2xxx.x;	NOISE:ATTEN:SET	Same as SCPI
\$QDATN2;	NOISE:ATTEN:SET?	Same as SCPI

This page intentionally left blank.